

RF



MATERIALS

Head & cover:
Aluminium alloy

Diffusor:
Zinc plated steel

Element support:
Polyamide
(aluminium alloy for FRF3+ and FRF4+)

Magnetic core:
Synthesized magnetic material

Seals:
NBR Nitrile
(FKM - on request fluoro-elastomer)

Indicator housing:
Brass

PRESSURE (ISO 10771-1:2002)

Max working:
1 MPa (10 bar)

Test:
1,5 MPa (15 bar)

Bursting:
3 MPa (30 bar)

Collapse, differential
for the filter element (ISO 2941):
1 MPa (10 bar)

BYPASS VALVE

Setting:
150 kPa (1,5 bar) \pm 10%

WORKING TEMPERATURE

From -25° to +110° C

COMPATIBILITY (ISO 2943:1999)

Full with fluids: HH-HL-HM-HV-HTG
(according to ISO 6743/4)
For fluids different than the above mentio-
ned, please contact our Sales Department.

APPLICATION EXAMPLE

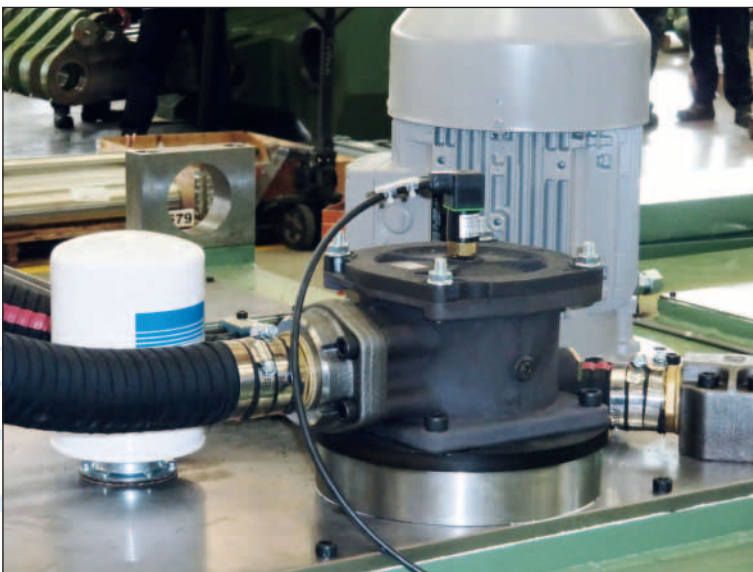

FRF 11 - 12 - 13 - 14
SINGLE PORT

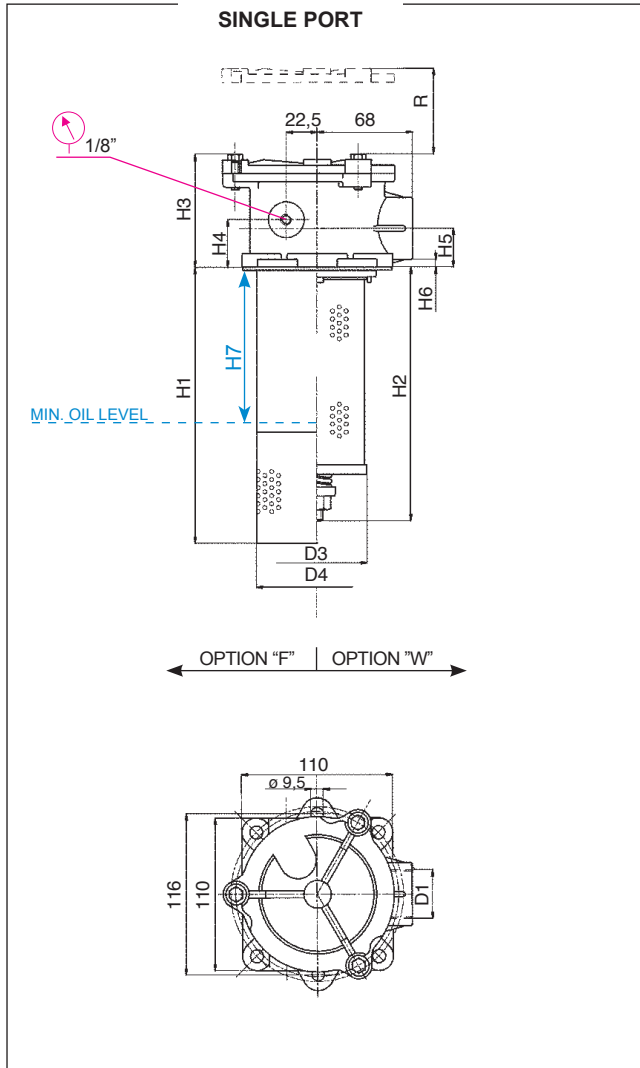

FRF 11 - 12 - 13 - 14
DOUBLE PORT

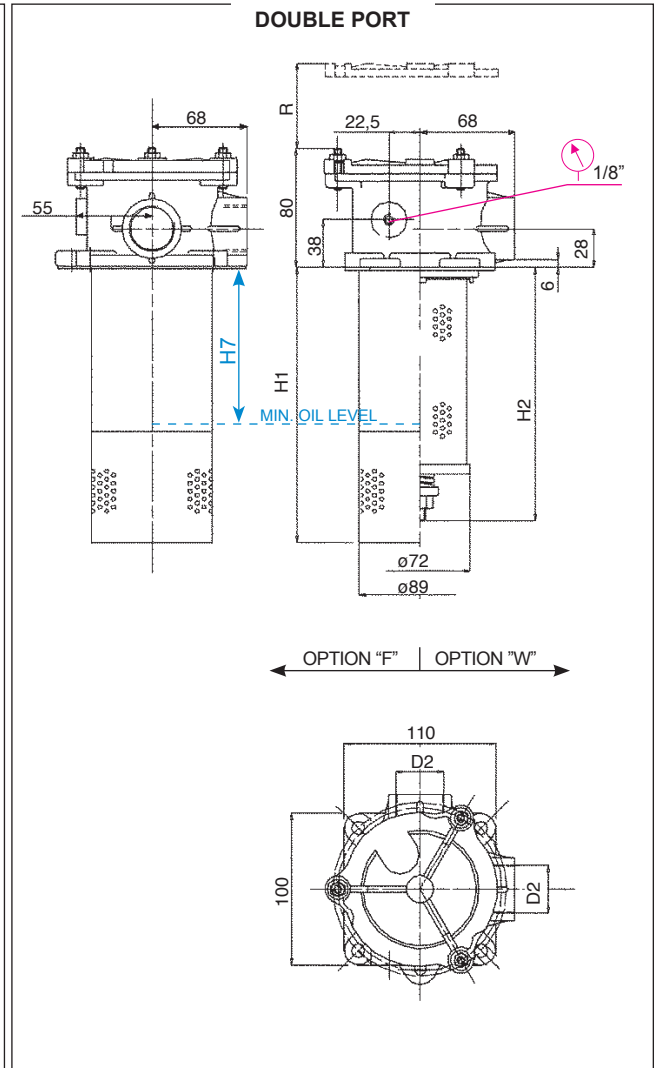

Tank mounting pattern
filter without diffusor

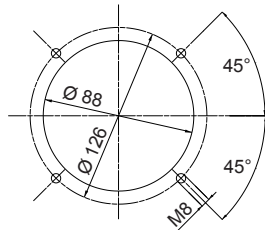

Tank mounting pattern
filter with diffusor

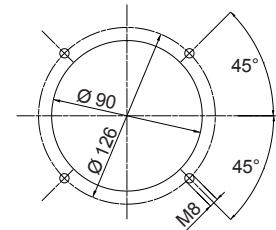

FILTER HOUSING

	D1	D2	D3	D4	H1	H2	H3	H4	H5	H6	H7	R	kg
FRF11	3/4" - 1" - 1" 1/4	1"	72	89	198	140	90	38	28÷32	6	118	230	1,2
FRF12	3/4" - 1" - 1" 1/4	1"	72	89	198	185	90	38	28÷32	6	118	275	1,4
FRF13	3/4" - 1" - 1" 1/4	1"	72	89	250	235	90	38	28÷32	6	170	325	1,5
FRF14	3/4" - 1" - 1" 1/4	1"	72	89	350	335	90	38	28÷32	6	270	445	1,7

TYPE											
F = FILTER COMPLETE		F	F	F	F						
B = FILTER HOUSING		B	B	B	B	ELEMENT	E				
R	F	FAMILY, NOMINAL SIZE & LENGTH				FAMILY SIZE & LENGTH		R	F		
		11	12	13	14						
PORT TYPE											
B = BSP thread		B	B	B	B						
A = BSP thread, double port (only A08)		A	A	A	A						
N = NPT thread		N	N	N	N						
S = SAE thread		S	S	S	S						
PORT SIZE											
06 = 3/4"		06	06	06	06						
08 = 1"		08	08	08	08						
10 = 1 1/4"		10	10	10	10						
F	BYPASS										
F = 150 kPa (1,5 bar)		F	F	F	F						
SEALS						SEALS					
N = NBR Nitrile		N	N	N	N	N = NBR					
F = FKM Fluoroelastomer		F	F	F	F	F = FKM					
FILTER MEDIA						FILTER MEDIA					
FA = fiber 5 $\mu\text{m}_{(e)}$ $\beta > 1.000$		FA	FA	FA	FA	FA = fiber 5 $\mu\text{m}_{(e)}$					
FB = fiber 7 $\mu\text{m}_{(e)}$ $\beta > 1.000$		FB	FB	FB	FB	FB = fiber 7 $\mu\text{m}_{(e)}$					
FC = fiber 12 $\mu\text{m}_{(e)}$ $\beta > 1.000$		FC	FC	FC	FC	FC = fiber 12 $\mu\text{m}_{(e)}$					
FD = fiber 21 $\mu\text{m}_{(e)}$ $\beta > 1.000$		FD	FD	FD	FD	FD = fiber 21 $\mu\text{m}_{(e)}$					
CC = cellulose 10 μm $\beta > 2$		CC	CC	CC	CC	CC = cellulose 10 μm					
ME = wire mesh 60 μm		ME	ME	ME	ME	ME = wire mesh 60 μm					
CLOGGING INDICATOR											
05 = nr. 2 x 1/8" ports, plugged		05	05	05	05						
30 = manometer, scale 0 - 600 kPa (0 - 6 bar)		30	30	30	30						
P4 = SPDT, pressure switch		P4	P4	P4	P4						
ACCESSORIES											
W = without accessory		W	W	W	W						
F = with diffusor		F	F	F	F						
ACCESSORIES											
W = without accessory		W	W	W	W						
M = magnetic core		M	M	M	M						

When the filter is ordered with FKM seals, the first digit of the indicator code is a letter (please see page 184 - 185).

FILTER ELEMENT

	A	B	C	kg	Area (cm ²)		
					Media F+	Media C+	Media M+
ERF11	45	72	106	0,25	770	1.250	460
ERF12	45	72	150	0,35	1.170	1.800	650
ERF13	45	72	200	0,45	1.570	2.450	880
ERF14	45	72	300	0,60	2.370	3.600	1.320

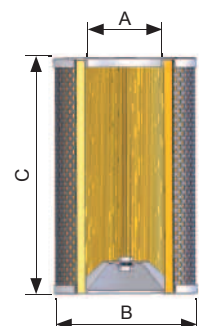

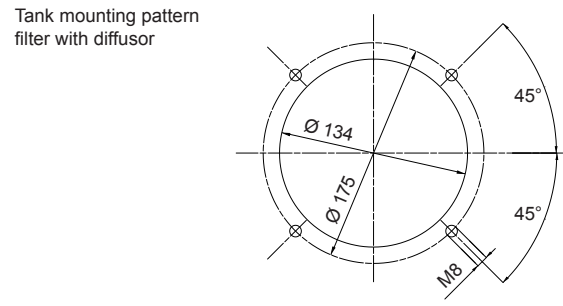
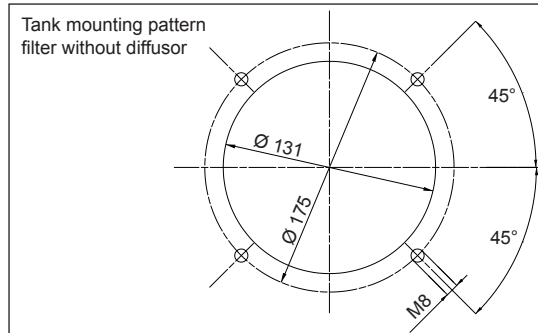
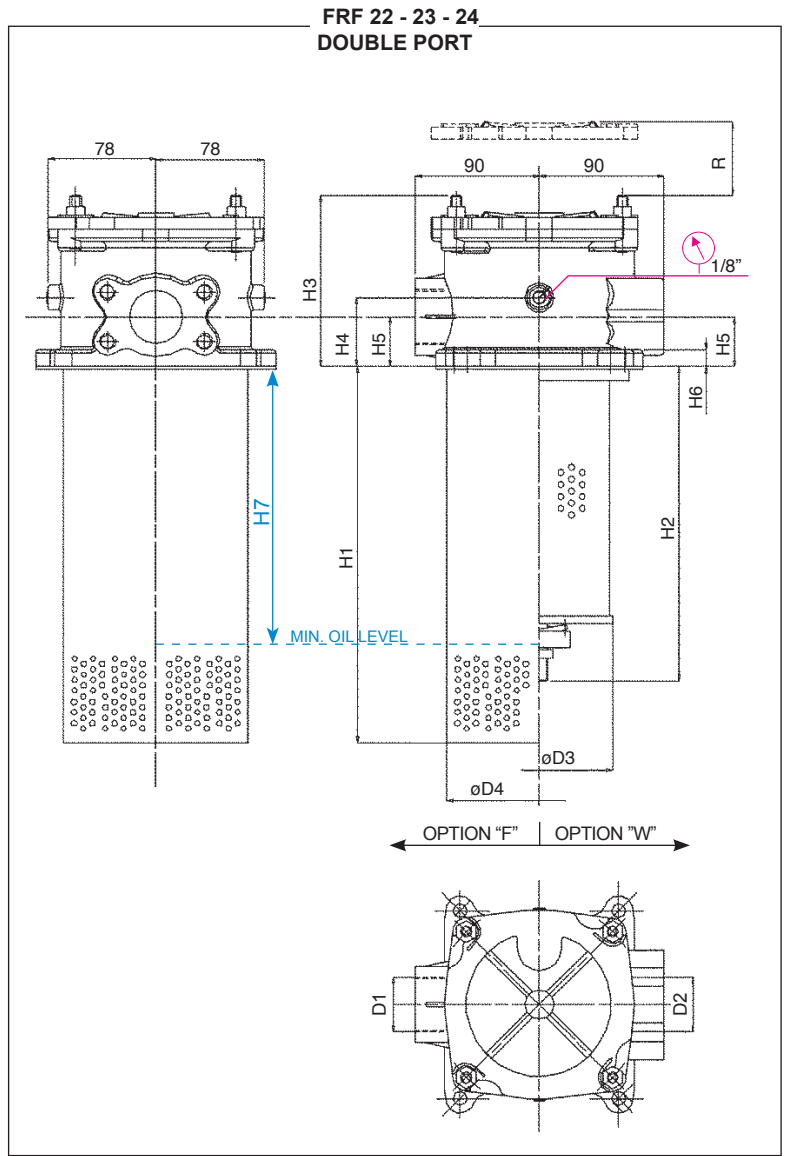
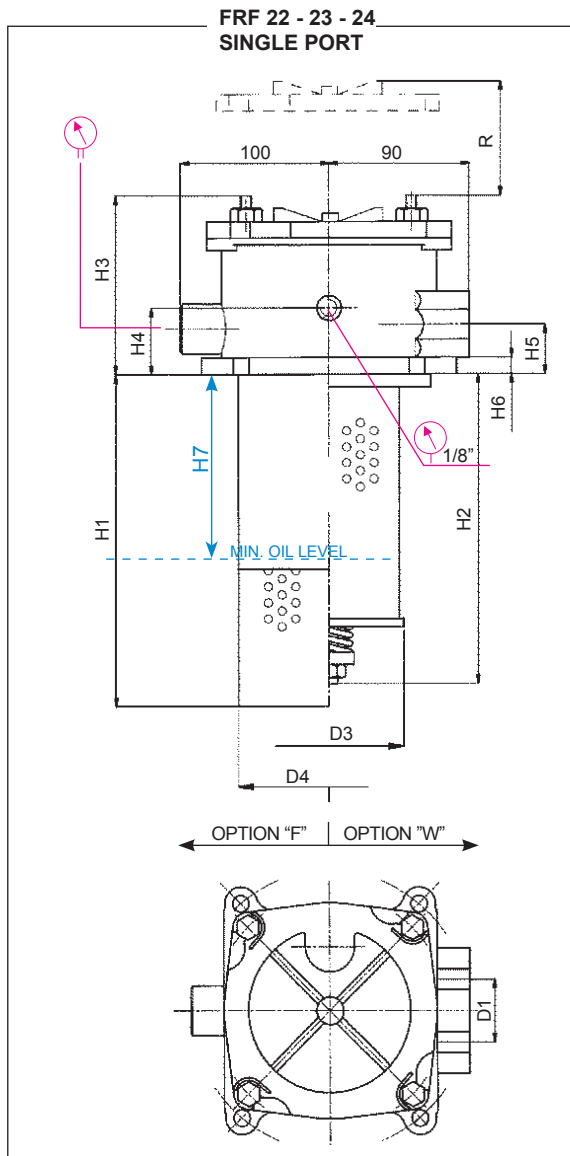

FILTER HOUSING

	D1	D2	D3	D4	H1	H2	H3	H4	H5	H6	H7	R	kg
FRF22	1" 1/2	1" 1/4 ÷ 1" 1/2	106	133	250	225	129	50	36	12	150	310	4,2
FRF23	1" 1/2	1" 1/4 ÷ 1" 1/2	106	133	320	295	129	50	36	12	220	380	4,7
FRF24	1" 1/2	1" 1/4 ÷ 1" 1/2	106	133	525	500	129	50	36	12	425	580	5,0

TYPE							
F = FILTER COMPLETE		F	F	F			
B = FILTER HOUSING		B	B	B	ELEMENT	E	
R	F	FAMILY, NOMINAL SIZE & LENGTH			FAMILY SIZE & LENGTH	R	F
		22	23	24			
PORT TYPE							
B = BSP thread		B	B	B			
A = BSP thread, double port (only AD1)		A	A	A			
N = NPT thread		N	N	N			
S = SAE thread		S	S	S			
F = SAE flange 3000 psi		F	F	F			
P = SAE thread 3000 psi, double port		P	P	P			
PORT SIZE							
12 = 1" 1/2		12	12	12			
D1 = 1" 1/2 + fl. 1" 1/4 (only AD1)		D1	D1	D1			
F	BYPASS						
F = 150 kPa (1,5 bar)		F	F	F			
SEALS					SEALS		
N = NBR Nitrile		N	N	N	N = NBR		
F = FKM Fluoroelastomer		F	F	F	F = FKM		
FILTER MEDIA					FILTER MEDIA		
FA = fiber 5 μm _(e) β>1.000		FA	FA	FA	FA = fiber 5 μm _(e)		
FB = fiber 7 μm _(e) β>1.000		FB	FB	FB	FB = fiber 7 μm _(e)		
FC = fiber 12 μm _(e) β>1.000		FC	FC	FC	FC = fiber 12 μm _(e)		
FD = fiber 21 μm _(e) β>1.000		FD	FD	FD	FD = fiber 21 μm _(e)		
CC = cellulose 10 μm β>2		CC	CC	CC	CC = cellulose 10 μm		
ME = wire mesh 60 μm		ME	ME	ME	ME = wire mesh 60 μm		
CLOGGING INDICATOR							
05 = nr. 2 x 1/8" ports, plugged		05	05	05	When the filter is ordered with FKM seals, the first digit of the indicator code is a letter (please see page 184 - 185).		
30 = manometer, scale 0 - 600 kPa (0 - 6 bar)		30	30	30			
P4 = SPDT, pressure switch		P4	P4	P4			
03 = port for differential indicator, plugged		03	03	03			
5B = visual differential 130 kPa (1,3 bar)		5B	5B	5B			
6B = electrical differential 130 kPa (1,3 bar)		6B	6B	6B			
7B = indicator 6B with LED		7B	7B	7B			
T0 = elect. diff. 130 kPa (1,3 bar) with thermostat 30°C		T0	T0	T0			
ACCESSORIES					N.B. Indicator series 70 only on request		
W = without accessory		W	W	W			
F = with diffusor		F	F	F			
ACCESSORIES							
W = without accessory		W	W	W			
M = magnetic core		M	M	M			

FILTER ELEMENT

	A	B	C	kg	Area (cm ²)		
					Media F+	Media C+	Media M+
ERF22	72	106	190	0,75	3.900	4.600	1.500
ERF23	72	106	260	1,00	5.400	6.400	2.050
ERF24	72	106	465	1,50	9.700	11.800	3.670

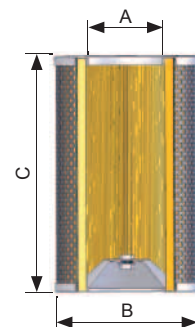

**FRF 31 - 32 - 33 - 34
SINGLE PORT**

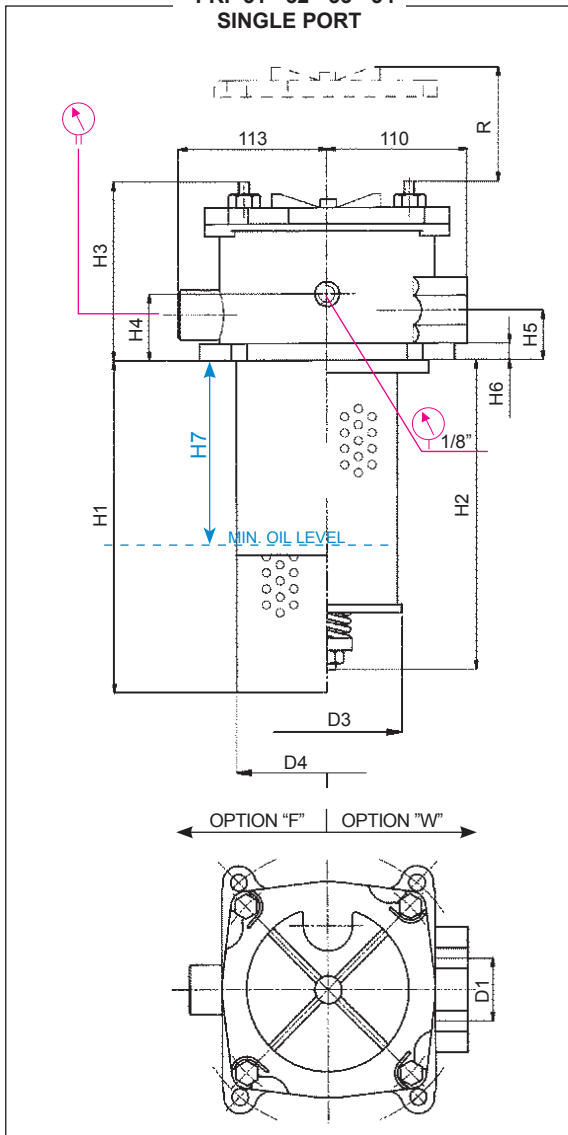

**FRF 31 - 32 - 33 - 34
DOUBLE PORT**

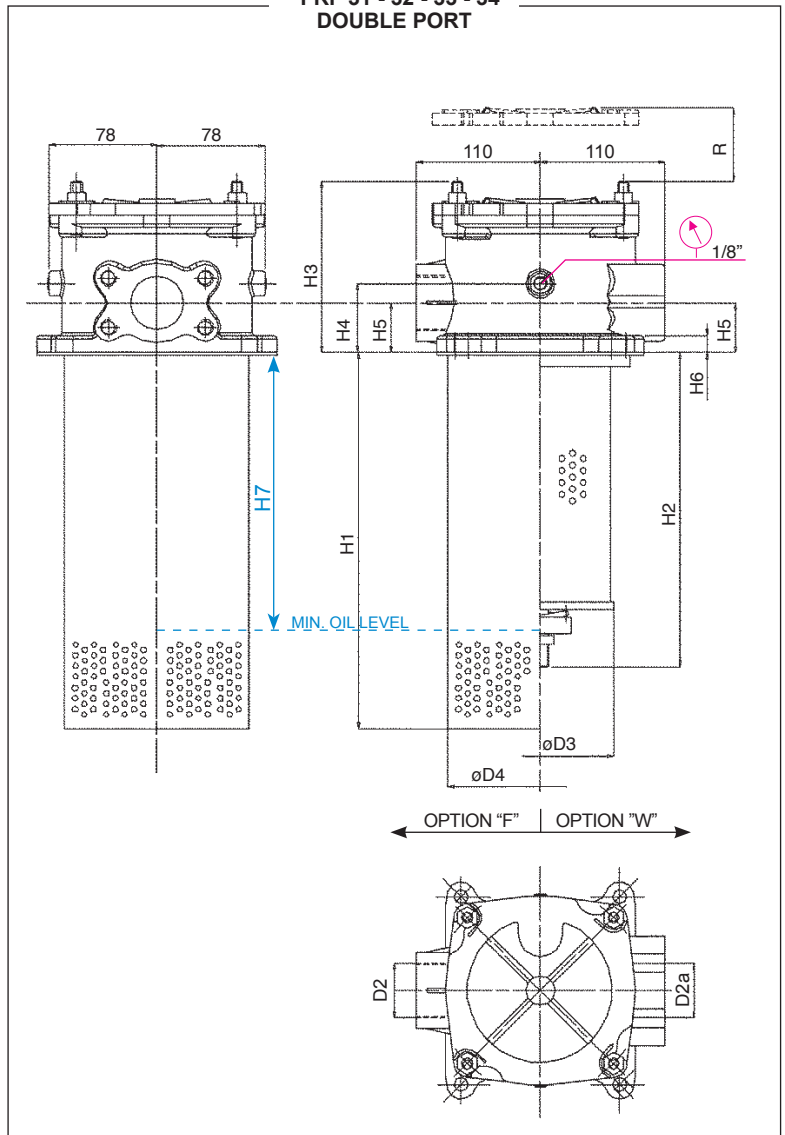

Tank mounting pattern
filter without diffusor

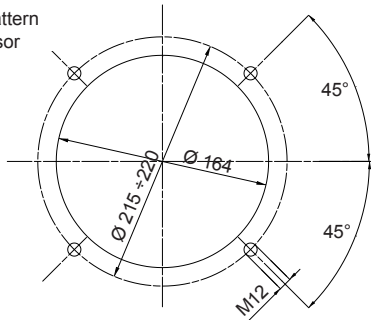

Tank mounting pattern
filter with diffusor

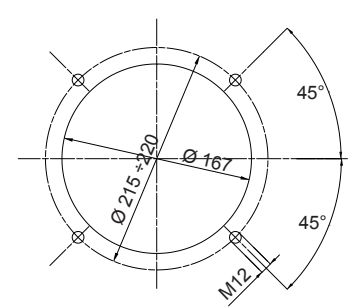

FILTER HOUSING

	D1	D2	D2a	D3	D4	H1	H2	H3	H4	H5	H6	H7	R	kg
FRF31	2" 1/2	2" - 2" 1/2	1" 1/2 - 2"	126	165,5	290	260	155	55	55	14	190	350	8,0
FRF32	2" 1/2	2" - 2" 1/2	1" 1/2 - 2"	126	165,5	370	340	155	55	55	14	270	430	8,4
FRF33	2" 1/2	2" - 2" 1/2	1" 1/2 - 2"	126	165,5	470	440	155	55	55	14	370	580	8,6
FRF34	2" 1/2	2" - 2" 1/2	1" 1/2 - 2"	126	165,5	560	530	155	55	55	14	460	620	9,1

TYPE									
F = FILTER COMPLETE		F	F	F	F				
B = FILTER HOUSING		B	B	B	B	ELEMENT	E		
R F	FAMILY, NOMINAL SIZE & LENGTH					FAMILY SIZE & LENGTH	R	F	
		31	32	33	34				
PORT TYPE									
F = SAE flange 3000 psi		F	F	F	F				
P = SAE thread 3000 psi, double port		P	P	P	P				
PORT SIZE									
20 = 2"1/2		20	20	20	20				
DA = 2"1/2 + 2"		DA	DA	DA	DA				
D7 = 2"+ 1"1/2		D7	D7	D7	D7				
F	BYPASS								
F = 150 kPa (1,5 bar)		F	F	F	F				
SEALS						SEALS			
N = NBR Nitrile		N	N	N	N	N = NBR			
F = FKM Fluoroelastomer		F	F	F	F	F = FKM			
FILTER MEDIA						FILTER MEDIA			
FA = fiber 5 μm(e) β>1.000		FA	FA	FA	FA	FA = fiber 5 μm(e)			
FB = fiber 7 μm(e) β>1.000		FB	FB	FB	FB	FB = fiber 7 μm(e)			
FC = fiber 12 μm(e) β>1.000		FC	FC	FC	FC	FC = fiber 12 μm(e)			
FD = fiber 21 μm(e) β>1.000		FD	FD	FD	FD	FD = fiber 21 μm(e)			
CC = cellulose 10 μm β>2		CC	CC	CC	CC	CC = cellulose 10 μm			
ME = wire mesh 60 μm		ME	ME	ME	ME	ME = wire mesh 60 μm			
CLOGGING INDICATOR									
05 = nr. 2 x 1/8" ports, plugged		05	05	05	05	When the filter is ordered with FKM seals, the first digit of the indicator code is a letter (please see page 184 - 185).			
30 = manometer, scale 0 - 600 kPa (0 - 6 bar)		30	30	30	30				
P4 = SPDT, pressure switch		P4	P4	P4	P4				
03 = port for differential indicator, plugged		03	03	03	03				
5B = visual differential 130 kPa (1,3 bar)		5B	5B	5B	5B				
6B = electrical differential 130 kPa (1,3 bar)		6B	6B	6B	6B				
7B = indicator 6B with LED		7B	7B	7B	7B	N.B. Indicator series 70 only on request			
T0 = elect. diff. 130 kPa (1,3 bar) with thermostat 30°C		T0	T0	T0	T0				
ACCESSORIES									
W = without accessory		W	W	W	W				
F = with diffusor		F	F	F	F				
ACCESSORIES									
W = without accessory		W	W	W	W				
M = magnetic core		M	M	M	M				

FILTER ELEMENT

	A	B	C	kg	Area (cm ²)		
					Media F+	Media C+	Media M+
ERF31	92	126	210	1,15	5.500	6.650	2.250
ERF32	92	126	290	1,50	7.700	9.200	3.150
ERF33	92	126	290	1,90	10.400	12.400	4.250
ERF34	92	126	480	2,20	12.800	15.400	5.250

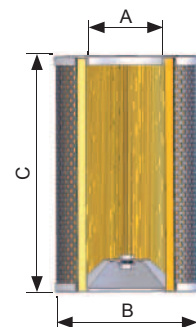

FRF 41 - 42 - 43 - 44
DOUBLE PORT

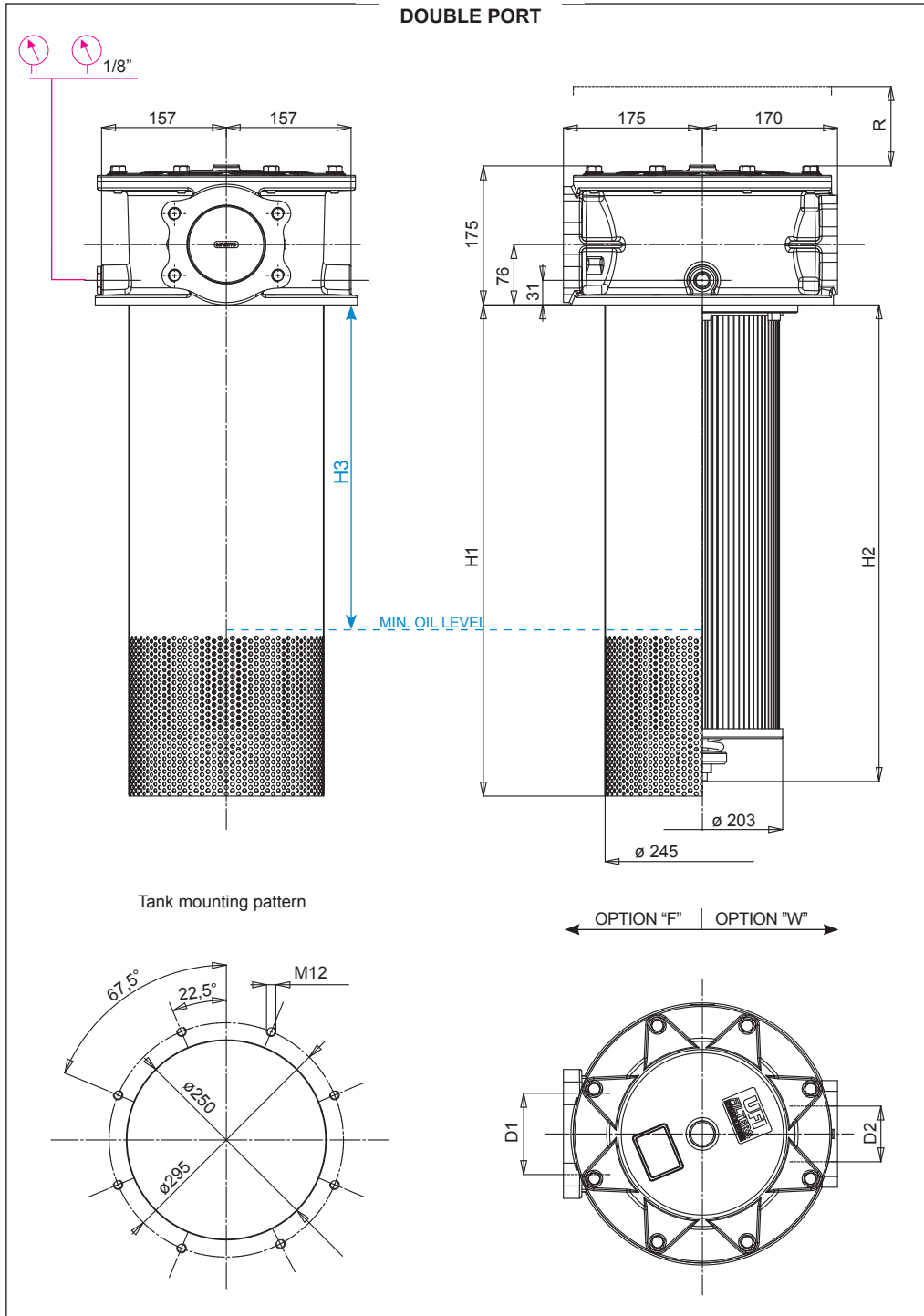

FILTER HOUSING

	D1	D2	H1	H2	H3	R
FRF41	3"	4"	405	396	205	600
FRF42	3"	4"	620	611	420	810
FRF43	3"	4"	900	891	700	1.090
FRF44	3"	4"	1.165	1.156	965	1.360

TYPE							
F = FILTER COMPLETE		F	F	F	F		
B = FILTER HOUSING		B	B	B	B	ELEMENT	E
R F	FAMILY, NOMINAL SIZE & LENGTH					FAMILY SIZE & LENGTH	R F
		41	42	43	44		
PORT TYPE							
F = SAE flange 3000 psi		F	F	F	F		
P = SAE thread 3000 psi, double port		P	P	P	P		
PORT SIZE							
24 = 3"		24	24	24	24		
32 = 4"		32	32	32	32		
D9 = 3"+ 4"		D9	D9	D9	D9		
F	BYPASS						
F = 150 kPa (1,5 bar)		F	F	F	F		
SEALS						SEALS	
N = NBR Nitrile		N	N	N	N	N = NBR	
F = FKM Fluoroelastomer		F	F	F	F	F = FKM	
FILTER MEDIA						FILTER MEDIA	
FA = fiber 5 μm _(e) β>1.000		FA	FA	FA	FA	FA = fiber 5 μm _(e)	
FB = fiber 7 μm _(e) β>1.000		FB	FB	FB	FB	FB = fiber 7 μm _(e)	
FC = fiber 12 μm _(e) β>1.000		FC	FC	FC	FC	FC = fiber 12 μm _(e)	
FD = fiber 21 μm _(e) β>1.000		FD	FD	FD	FD	FD = fiber 21 μm _(e)	
CC = cellulose 10 μm β>2		CC	CC	CC	CC	CC = cellulose 10 μm	
ME = wire mesh 60 μm		ME	ME	ME	ME	ME = wire mesh 60 μm	
CLOGGING INDICATOR							
05 = nr. 2 x 1/8" ports, plugged		05	05	05	05	When the filter is ordered with FKM seals, the first digit of the indicator code is a letter (please see page _____).	
30 = manometer, scale 0 - 600 kPa (0 - 6 bar)		30	30	30	30		
P4 = SPDT, pressure switch		P4	P4	P4	P4		
03 = port for differential indicator, plugged		03	03	03	03		
5B = visual differential 130 kPa (1,3 bar)		5B	5B	5B	5B		
6B = electrical differential 130 kPa (1,3 bar)		6B	6B	6B	6B		
7B = indicator 6B with LED		7B	7B	7B	7B		
T0 = elect. diff. 130 kPa (1,3 bar) with thermostat 30°C		T0	T0	T0	T0	N.B. Indicator series 70 only on request	
ACCESSORIES							
W = without accessory		W	W	W	W		
F = with diffusor		F	F	F	F		
ACCESSORIES							
W = without accessory		W	W	W	W		
M = magnetic core		M	M	M	M		

FILTER ELEMENT

	A	B	C	kg	Area (cm ²)		
					Media F+	Media C+	Media M+
ERF41	157	203	330	3,90	17.900	22.100	6.400
ERF42	157	203	545	5,20	30.000	37.000	10.800
ERF43	157	203	825	9,00	45.200	55.500	16.200
ERF44	157	203	1.090	13,00	60.000	74.000	21.800

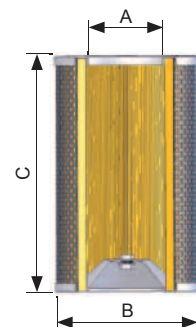

FLUID SPEED

when selecting the filter size, we suggest to consider also the max recommended fluid speed (in return lines normally $1,5 < v < 4 \text{ m/s}$)

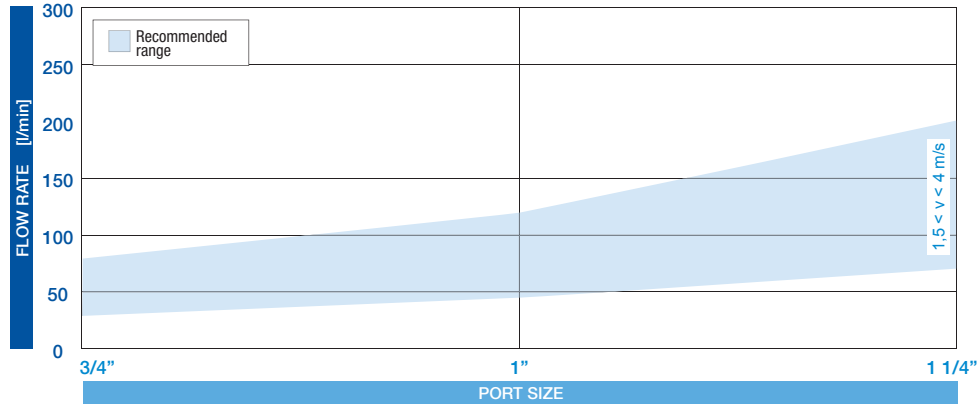

1+ DIAGRAMS

PRESSURE DROP CURVES (Δp)

The "Assembly Pressure Drop (Δp)" is obtained by adding the pressure drop values of the Filter Housing and of the Clean Filter Element corresponding to the considered Flow Rate and it must be lower than 50 kPa (0,5 bar).

FILTER HOUSING PRESSURE DROP (mainly depending on the port size)

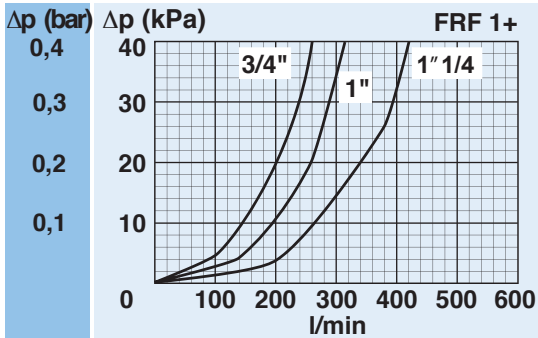

BYPASS VALVE PRESSURE DROP

When selecting the filter size, these curves must be taken into account if it is foreseen that any flow peak is to be absorbed by the bypass valve, it also must be of proper configuration to avoid pressure peaks. The valve pressure drop is directly proportional to fluid specific gravity.

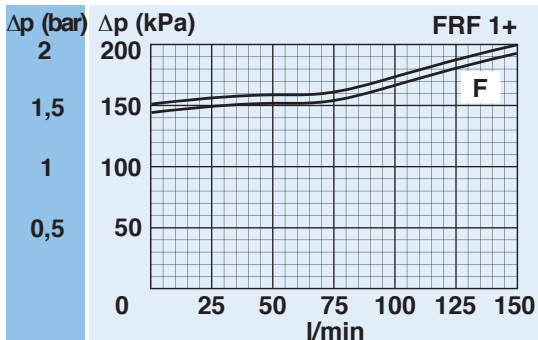

CLEAN FILTER ELEMENT PRESSURE DROP WITH F+, C+ AND ME MEDIA (depending both on the internal diameter of the element and on the filter media)

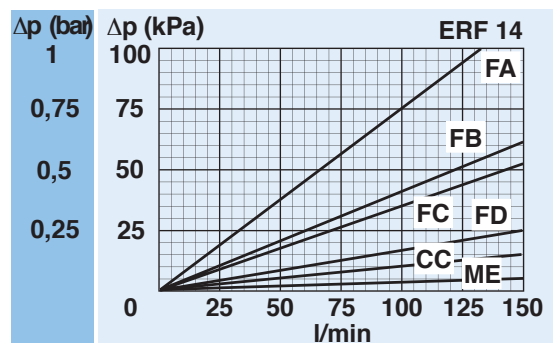
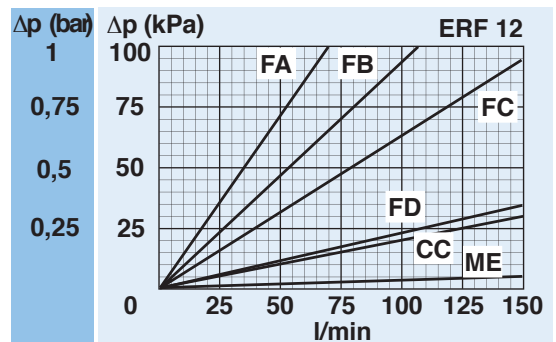
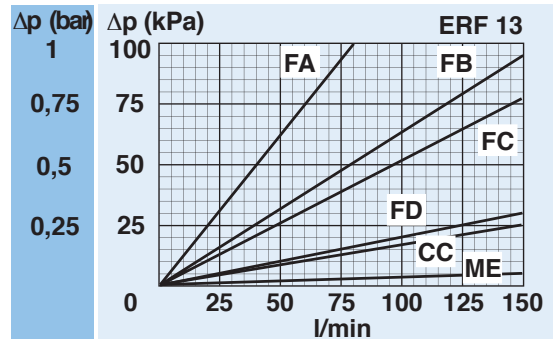
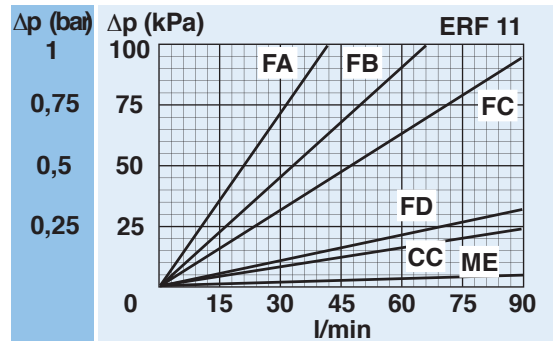

N.B. All the curves have been obtained with mineral oil having a kinematic viscosity 30 cSt and specific gravity 0,9 kg/dm³; for fluids with different features, please consider the factors described in the first part of this catalogue. All the curves are obtained from test done at the UFI HYDRAULIC DIVISION Laboratory, according to the specification ISO 3968:2005. In case of discrepancy, please check the contamination level, viscosity and features of the fluid in use.

FLUID SPEED

when selecting the filter size, we suggest to consider also the max recommended fluid speed (in return lines normally $1,5 < v < 4$ m/s)

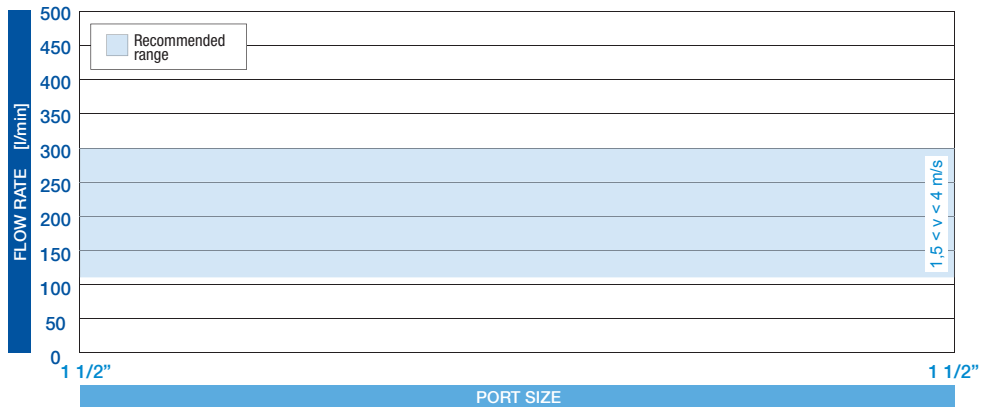

2+ DIAGRAMS

PRESSURE DROP CURVES (Δp)

The "Assembly Pressure Drop (Δp)" is obtained by adding the pressure drop values of the Filter Housing and of the Clean Filter Element corresponding to the considered Flow Rate and it must be lower than 50 kPa (0,5 bar).

FILTER HOUSING PRESSURE DROP
(mainly depending on the port size)

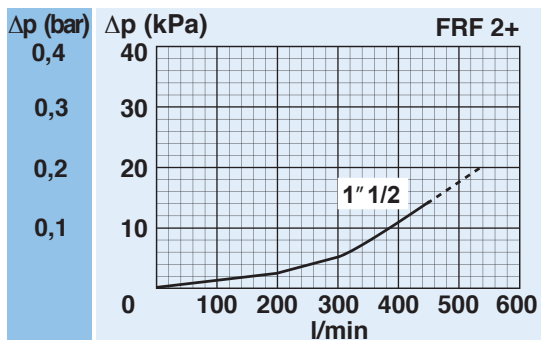

BYPASS VALVE PRESSURE DROP

When selecting the filter size, these curves must be taken into account if it is foreseen that any flow peak is to be absorbed by the bypass valve, it also must be of proper configuration to avoid pressure peaks. The valve pressure drop is directly proportional to fluid specific gravity.

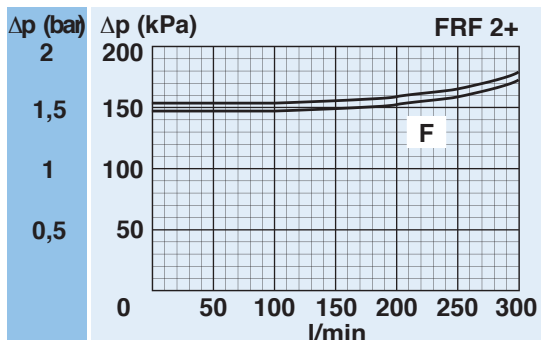

CLEAN FILTER ELEMENT PRESSURE DROP WITH F+, C+ AND ME MEDIA

(depending both on the internal diameter of the element and on the filter media)

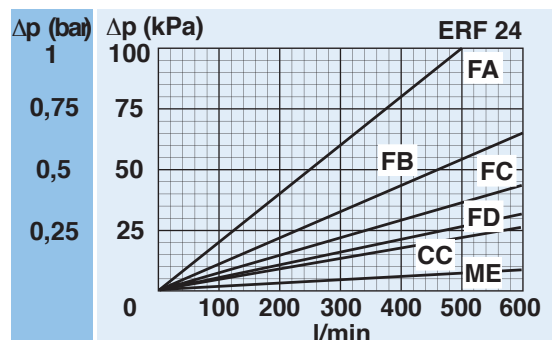
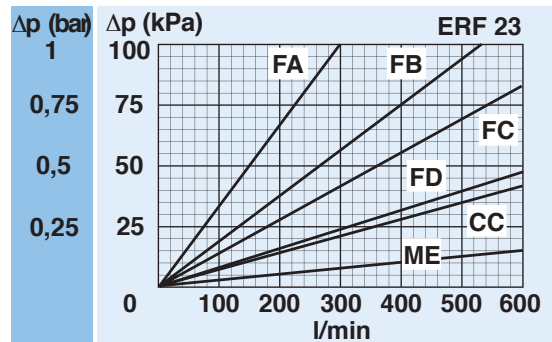
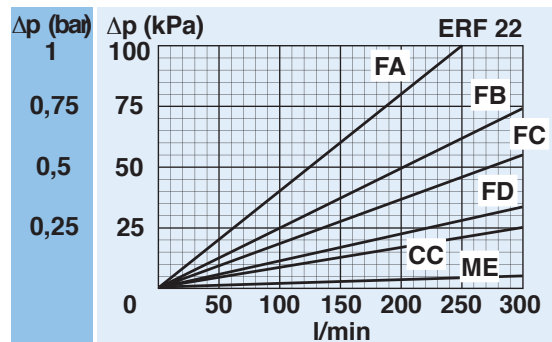

N.B. All the curves have been obtained with mineral oil having a kinematic viscosity 30 cSt and specific gravity 0,9 kg/dm³; for fluids with different features, please consider the factors described in the first part of this catalogue. All the curves are obtained from test done at the UFI HYDRAULIC DIVISION Laboratory, according to the specification ISO 3968:2005. In case of discrepancy, please check the contamination level, viscosity and features of the fluid in use.

FLUID SPEED

when selecting the filter size, we suggest to consider also the max recommended fluid speed (in return lines normally $1,5 < v < 4$ m/s)

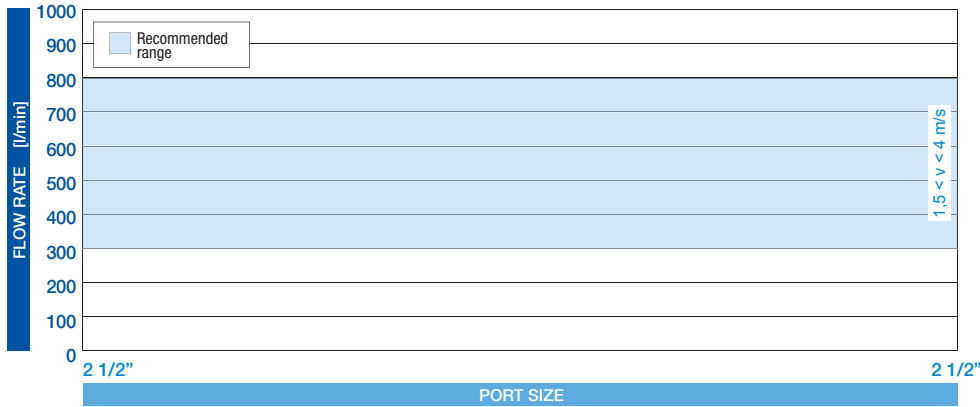

3+ DIAGRAMS

PRESSURE DROP CURVES (Δp)

The “Assembly Pressure Drop (Δp)” is obtained by adding the pressure drop values of the Filter Housing and of the Clean Filter Element corresponding to the considered Flow Rate and it must be lower than 50 kPa (0,5 bar).

FILTER HOUSING PRESSURE DROP
(mainly depending on the port size)

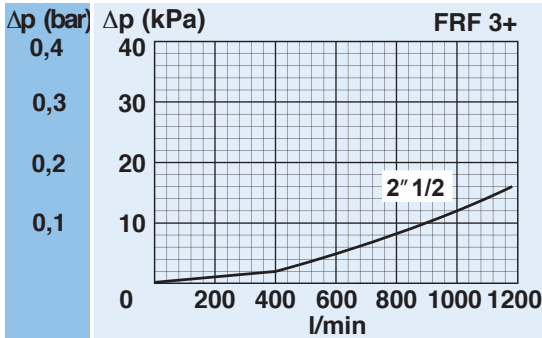

BYPASS VALVE PRESSURE DROP

When selecting the filter size, these curves must be taken into account if it is foreseen that any flow peak is to be absorbed by the bypass valve, it also must be of proper configuration to avoid pressure peaks. The valve pressure drop is directly proportional to fluid specific gravity.

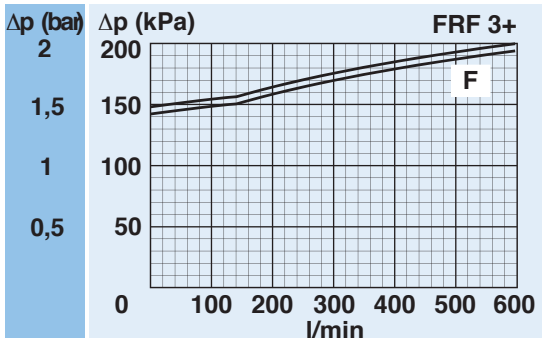

CLEAN FILTER ELEMENT PRESSURE DROP WITH F+, C+ AND ME MEDIA
(depending both on the internal diameter of the element and on the filter media)

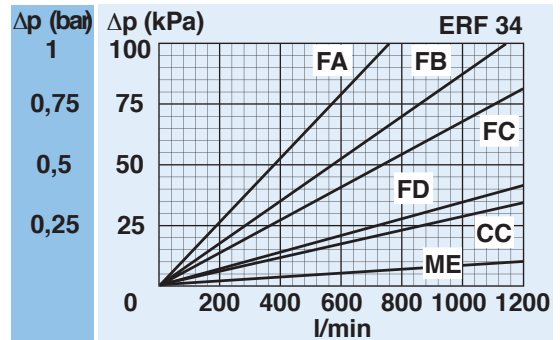
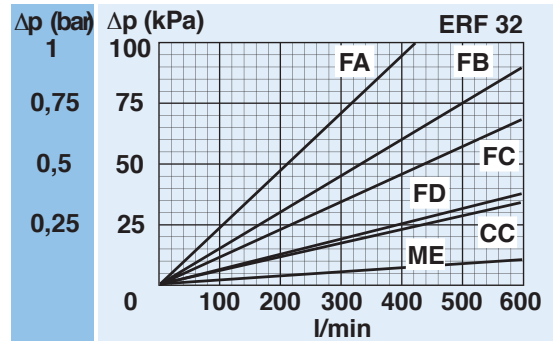
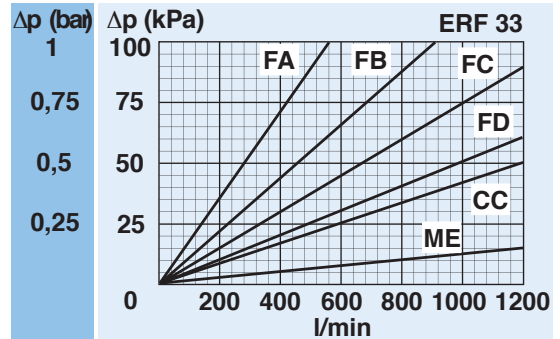
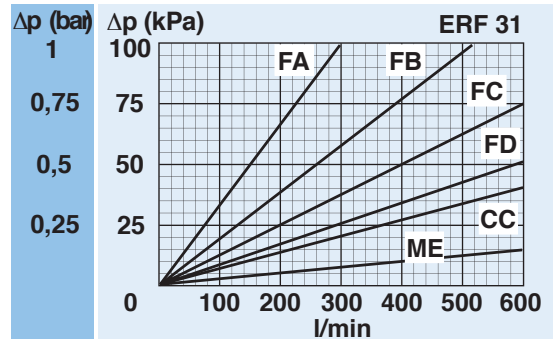

N.B. All the curves have been obtained with mineral oil having a kinematic viscosity 30 cSt and specific gravity 0,9 kg/dm³; for fluids with different features, please consider the factors described in the first part of this catalogue. All the curves are obtained from test done at the UFI HYDRAULIC DIVISION Laboratory, according to the specification ISO 3968:2005. In case of discrepancy, please check the contamination level, viscosity and features of the fluid in use.

FLUID SPEED

when selecting the filter size, we suggest to consider also the max recommended fluid speed (in return lines normally $1,5 < v < 4$ m/s)

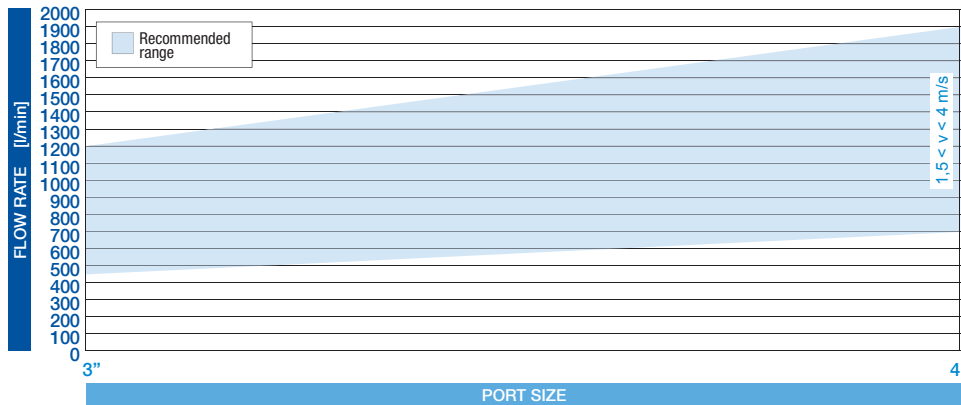

4+ DIAGRAMS

PRESSURE DROP CURVES (Δp)

The “Assembly Pressure Drop (Δp)” is obtained by adding the pressure drop values of the Filter Housing and of the Clean Filter Element corresponding to the considered Flow Rate and it must be lower than 50 kPa (0,5 bar).

FILTER HOUSING PRESSURE DROP
(mainly depending on the port size)

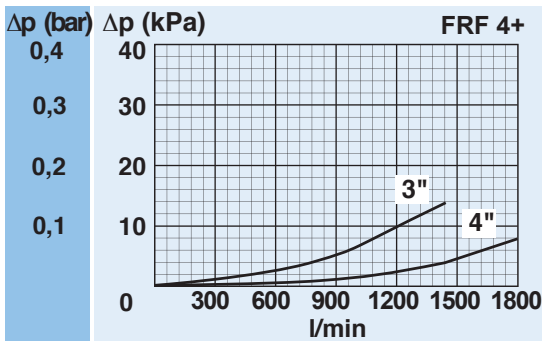

BYPASS VALVE PRESSURE DROP

When selecting the filter size, these curves must be taken into account if it is foreseen that any flow peak is to be absorbed by the bypass valve, it also must be of proper configuration to avoid pressure peaks. The valve pressure drop is directly proportional to fluid specific gravity.

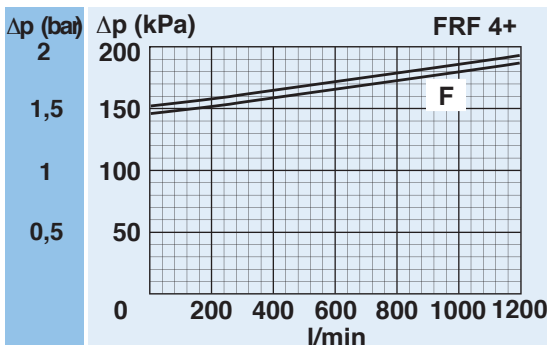

CLEAN FILTER ELEMENT PRESSURE DROP WITH F+, C+ AND ME MEDIA

(depending both on the internal diameter of the element and on the filter media)

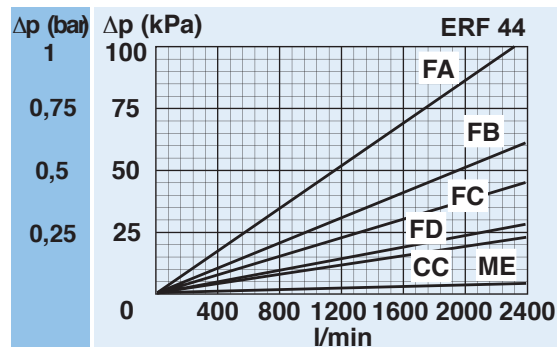
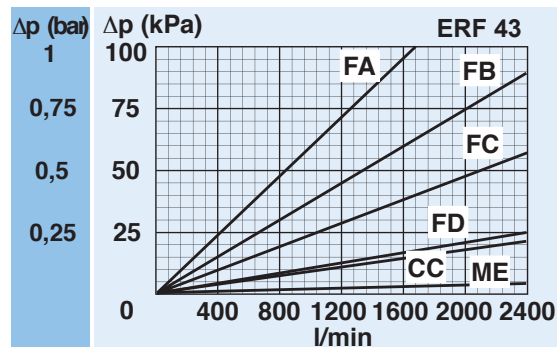
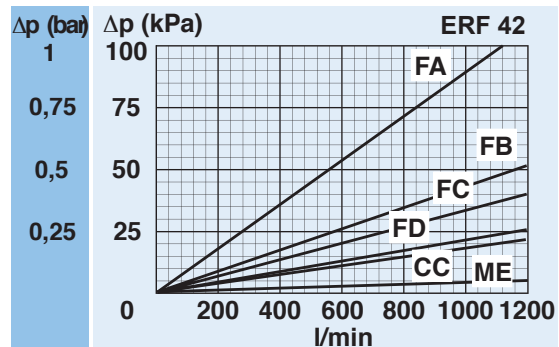
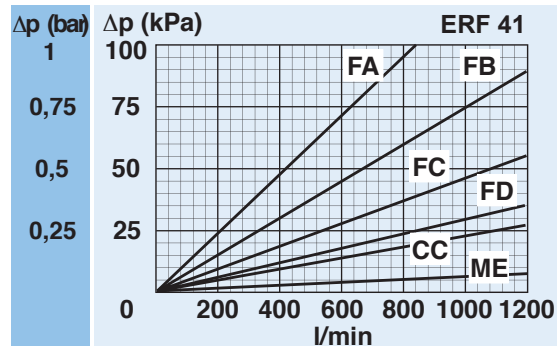

N.B. All the curves have been obtained with mineral oil having a kinematic viscosity 30 cSt and specific gravity 0,9 kg/dm³; for fluids with different features, please consider the factors described in the first part of this catalogue. All the curves are obtained from test done at the UFI HYDRAULIC DIVISION Laboratory, according to the specification ISO 3968:2005. In case of discrepancy, please check the contamination level, viscosity and features of the fluid in use.

CLOGGING INDICATOR

A visual or differential indicator (differential indicator with thermostat is an available option) allows monitoring of the element condition and provides maximum element life by indicating the exact time for the element replacement. The port for the indicator is a standard feature.

MAGNETIC CORE

The magnetic core (available as an option) ensures a magnetic pre-filtration of ferrous particles, even during bypass conditions.

DIFFUSOR

The diffusor (available as an option) smooths the oil flow thus reducing turbulence inside the tank even in case of large flow rates.

INSIDE TO OUTSIDE FILTRATION

"Inside-to-outside" filtration ensures the contaminant is retained inside the element during replacement; also filling or top-up of the reservoir can be done through the filter thus avoiding the ingress of new contaminant.

BYPASS

The bypass function is obtained by the filter element moving axially, in such a way that the contaminant is retained in the filter element during bypass conditions.

CLOGGING INDICATOR

For further technical informations and other options see page 184-185.

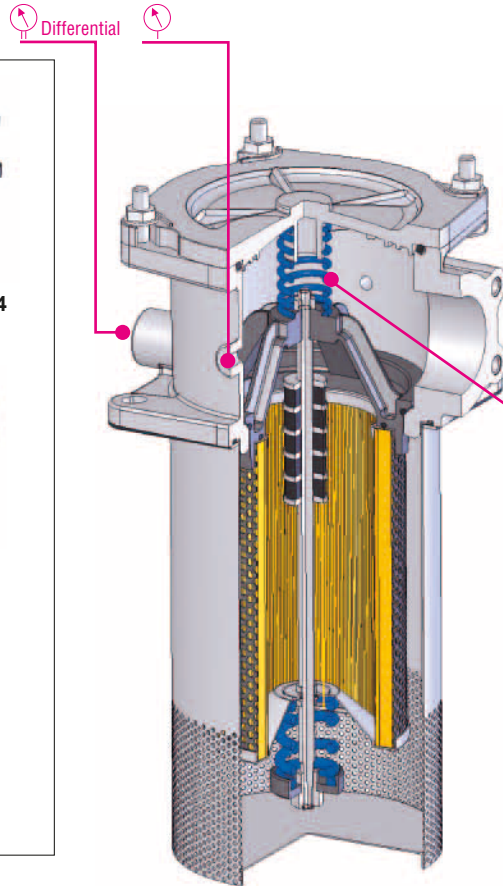

SPARE SEAL KIT

	NBR	FKM
FRF11	521.0055.2	521.0056.2
FRF12	521.0055.2	521.0056.2
FRF13	521.0055.2	521.0056.2
FRF14	521.0055.2	521.0056.2
FRF22	521.0020.2	521.0057.2
FRF23	521.0020.2	521.0057.2
FRF24	521.0020.2	521.0057.2
FRF31	521.0021.2	521.0058.2
FRF32	521.0021.2	521.0058.2
FRF33	521.0021.2	521.0058.2
FRF34	521.0021.2	521.0058.2
FRF41	521.0095.2	521.0096.2
FRF42	521.0095.2	521.0096.2
FRF43	521.0095.2	521.0096.2
FRF44	521.0095.2	521.0096.2

SPARE SPRING

FRF11	008.0282.1
FRF12	008.0282.1
FRF13	008.0282.1
FRF14	008.0282.1
FRF22	008.0269.1
FRF23	008.0269.1
FRF24	008.0269.1
FRF31	008.0275.1
FRF32	008.0275.1
FRF33	008.0275.1
FRF34	008.0275.1
FRF41	008.0283.1
FRF42	008.0283.1
FRF43	008.0283.1
FRF44	008.0283.1

SPARE PARTS ELEMENTS

(For filling up see table "Ordering and option chart")

FILTER HOUSING	FILTER ELEMENT	CLOGGING INDICATOR	ACCESSORY	ACCESSORY
<input type="checkbox"/> F <input type="checkbox"/> R <input type="checkbox"/> B <input type="checkbox"/> F	<input type="checkbox"/> E <input type="checkbox"/> R <input type="checkbox"/> F	<input type="checkbox"/>	<input type="checkbox"/> MAGNETIC CORE	<input type="checkbox"/> DIFFUSOR



Is this datasheet the latest release? Please check on our website.

