

RB



MATERIALS

Head:
Aluminium alloy

Cover & bowl:
Polyamide

Bypass valve:
Polyamide

Seals:
NBR Nitrile

Indicator housing:
Brass

PRESSURE (ISO 10771-1:2002)

Max working:
700 kPa (7 bar)

Test:
1 MPa (10 bar)

Bursting:
2,1 MPa (21 bar)

Collapse, differential
for the filter element (ISO 2941):
300 kPa (3 bar)

BYPASS VALVE

Setting:
170 kPa (1,7 bar) $\pm 10\%$

WORKING TEMPERATURE

From -25° to $+110^{\circ}$ C

COMPATIBILITY (ISO 2943:1999)

Full with fluids: HH-HL-HM-HV-HTG
(according to ISO 6743/4)
For fluids different than the above mentioned,
please contact our Sales Department.

APPLICATION EXAMPLE



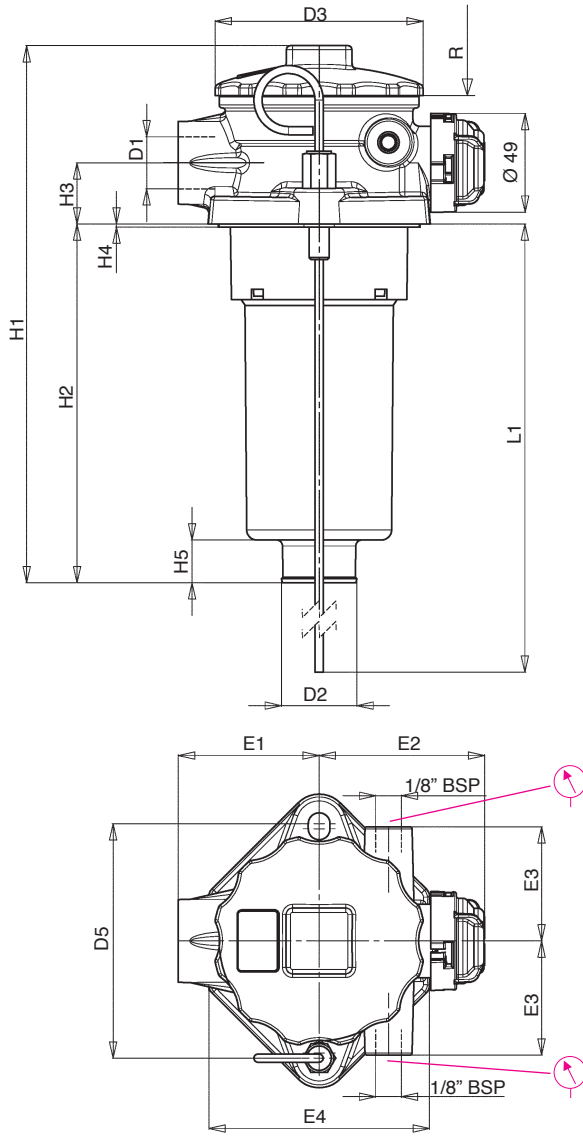

Tank mounting pattern

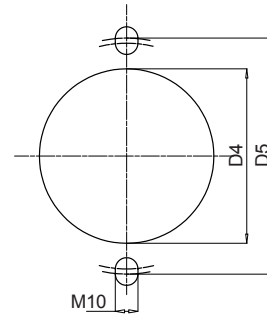

FILTER HOUSING

	D1	D2	D3	D4	D5	E1	E2	E3	E4	H1	H2	H3	H4	H5	L1	R	kg
FRB11	1/2" - 3/4"	28	75	61	82+88	50	70	28	77	243	178	24	2	16	380	220	0,40
FRB21	3/4" - 1"	36	104	89	110+115	70	83	37	108	200	110	30	1,5	22	370	190	0,84
FRB22	3/4" - 1"	36	104	89	110+115	70	83	37	108	265	175	30	1,5	22	370	240	0,87
FRB23	3/4" - 1"	36	104	89	110+115	70	83	37	108	365	275	30	1,5	22	370	350	0,92

		TYPE					
		F = FILTER COMPLETE	F	F	F	F	
		B = FILTER HOUSING	B	B	B	B	ELEMENT E
R	B	FAMILY NOMINAL SIZE & LENGTH				FAMILY SIZE & LENGTH R B	
		11	21	22	23		
		PORT TYPE					
		B = BSP thread	B	B	B	B	
		N = NPT thread	N	N	N	N	
		S = SAE thread	S	S	S	S	
		PORT SIZE					
		04 = 1/2"	04	-	-	-	
		06 = 3/4"	06	06	06	06	
		08 = 1"	-	08	08	08	
B		BYPASS VALVE					
		B = 170 kPa (1,7 bar)- 250 kPa (2,5 bar) for media F+	B	B	B	B	
N		SEALS				SEALS N	
		N = NBR Nitrile	N	N	N	N	N = NBR
		FILTER MEDIA				FILTER MEDIA	
		FA = fiber 5 μm _(c) β>1.000	FA	FA	FA	FA	FA = fiber 5 μm _(c)
		FB = fiber 7 μm _(c) β>1.000	FB	FB	FB	FB	FB = fiber 7 μm _(c)
		FC = fiber 12 μm _(c) β>1.000	FC	FC	FC	FC	FC = fiber 12 μm _(c)
		FD = fiber 21 μm _(c) β>1.000	FD	FD	FD	FD	FD = fiber 21 μm _(c)
		CC = cellulose 10 μm β>2	CC	CC	CC	CC	CC = cellulose 10 μm
		CD = cellulose 25 μm β>2	CD	CD	CD	CD	CD = cellulose 25 μm
		CLOGGING INDICATORS					
		05 = nr. 2 x 1/8" ports, plugged	05	05	05	05	
		30 = pressure gauge, rear connection	30	30	30	30	
		P1 = SPDT, pressure switch	P1	P1	P1	P1	
		P6 = SPDT, pressure switch	P6	P6	P6	P6	
		ACCESSORIES					
		W = without	W	W	W	W	
		C = with paper air filter	C	C	C	C	
		D = with metal air filter	D	D	D	D	
		ACCESSORIES					
		W = without	W	W	W	W	
		H = with dipstick	H	H	H	H	

FILTER ELEMENT

	A	B	C	kg	Area (cm ²)	
					Media F+	Media C+
ERB11	43	20	200	0,20	1.225	1.225
ERB21	59	28	134	0,30	1.500	1.500
ERB22	59	28	200	0,40	2.295	2.295
ERB23	59	28	300	0,50	3.495	3.495

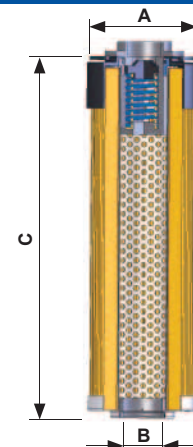

FLUID SPEED

when selecting the filter size, we suggest to consider also the max recommended fluid speed (in return lines normally $1,5 < v < 4$ m/s)

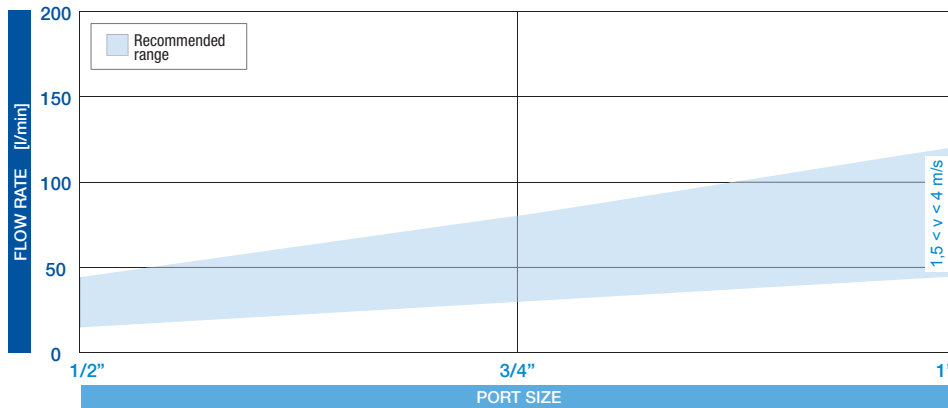

PRESSURE DROP CURVES (Δp)

The “Assembly Pressure Drop (Δp)” is obtained by adding the pressure drop values of the Filter Housing and of the Clean Filter Element corresponding to the considered Flow Rate and it must be lower than 50 kPa (0,5 bar).

FILTER HOUSING PRESSURE DROP
(mainly depending on the port size)

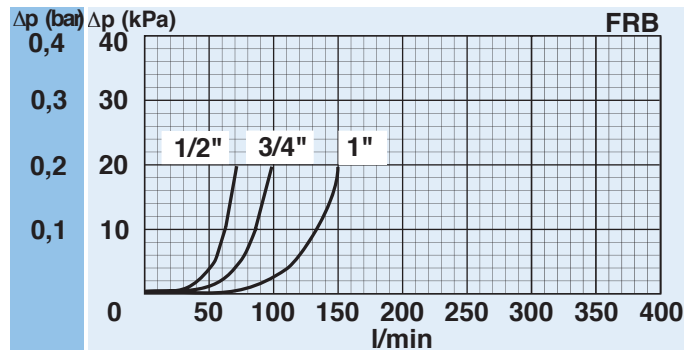

N.B. All the curves have been obtained with mineral oil having a kinematic viscosity 30 cSt and specific gravity 0,9 kg/dm³; for fluids with different features, please consider the factors described in the first part of this catalogue. All the curves are obtained from test done at the UFI HYDRAULIC DIVISION Laboratory, according to the specification ISO 3968:2005. In case of discrepancy, please check the contamination level, viscosity and features of the fluid in use.

PRESSURE DROP CURVES (Δp)

The “Assembly Pressure Drop (Δp)” is obtained by adding the pressure drop values of the Filter Housing and of the Clean Filter Element corresponding to the considered Flow Rate and it must be lower than 50 kPa (0,5 bar).

CLEAN FILTER ELEMENT PRESSURE DROP WITH F+ AND C+ MEDIA

(depending both on the internal diameter of the element and on the filter media)

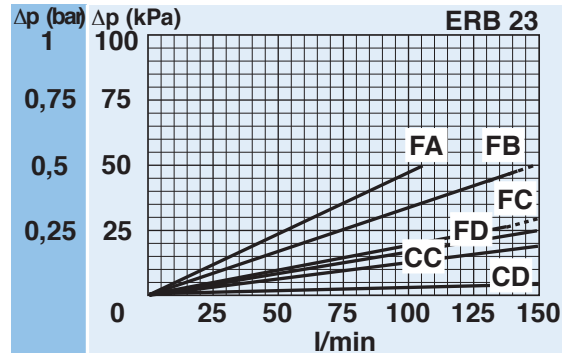
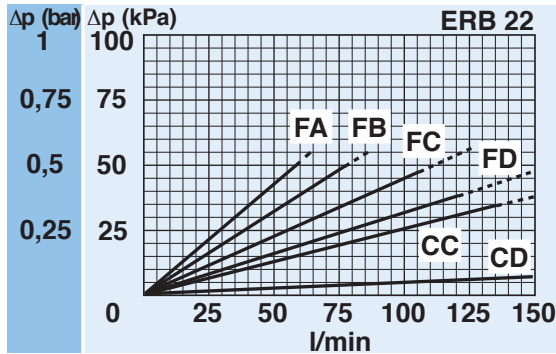
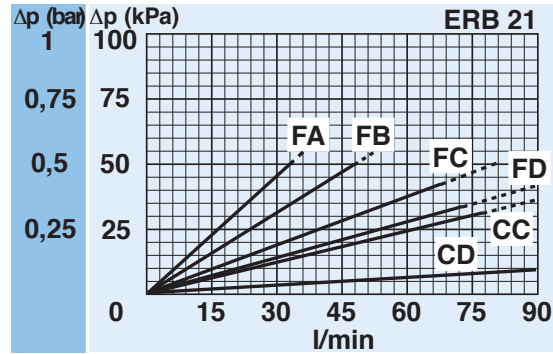
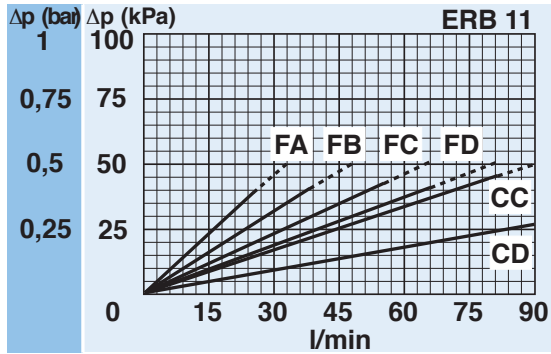

BYPASS VALVE PRESSURE DROP

When selecting the filter size, these curves must be taken into account if it is foreseen that any flow peak is to be absorbed by the bypass valve, it also must be of proper configuration to avoid pressure peaks. The valve pressure drop is directly proportional to fluid specific gravity.

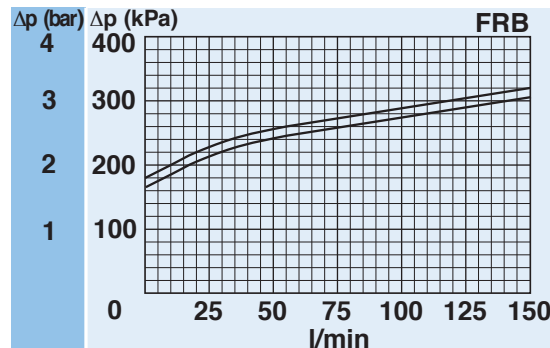

N.B. All the curves have been obtained with mineral oil having a kinematic viscosity 30 cSt and specific gravity 0,9 kg/dm³; for fluids with different features, please consider the factors described in the first part of this catalogue. All the curves are obtained from test done at the UFI HYDRAULIC DIVISION Laboratory, according to the specification ISO 3968:2005. In case of discrepancy, please check the contamination level, viscosity and features of the fluid in use.

CLOGGING INDICATOR

A visual or electrical indicator is available as an option and allows monitoring of the element condition. The port for the indicator is a standard feature.

DIPSTICK

The (optional) dipstick allows to check the oil level, with no need for a visual level gauge, thus saving space and costs.

EASY REPLACEMENT

The top end cap includes a handle allowing an easy removal of the element and complete cleaning of the bowl.

QUICK MAINTENANCE

Thanks to a threaded cap no tool is needed when replacing the element.

AIR BREATHER

The built in air breather joins in one product even the air filtration function.

NO LEAKS

The end cap with captive O-ring ensures a perfect sealing between filter element and bowl.

CLOGGING INDICATOR

For further technical informations and other options see page 184.

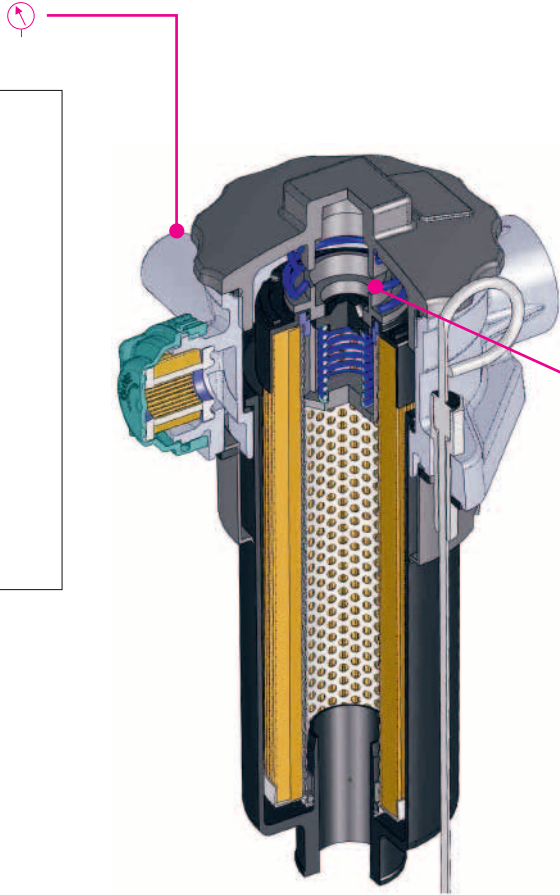

SPARE SEAL KIT

NBR	
FRB11	521.0016.2
FRB21	521.0017.2
FRB22	521.0017.2
FRB23	521.0017.2

SPARE SPRING

FRB11	008.0208.1
FRB21	008.3014.1
FRB22	008.3014.1
FRB23	008.3014.1

SPARE PARTS ELEMENTS

(For filling up see table "Ordering and option chart")

FILTER HOUSING	FILTER ELEMENT	CLOGGING INDICATOR	ACCESSORY	ACCESSORY
 <input type="checkbox"/>	 <input type="checkbox"/>	 <input type="checkbox"/>	 <input type="checkbox"/> DIPSTICK	 <input type="checkbox"/> AIR FILTER



Is this datasheet the latest release? Please check on our website.

