



**DIPLOMATIC  
HYDRAULICS**

96 000/108 ED



# CTR\*

## HYDRAULIC POWER UNITS

### TANK CAPACITY

from 8 lt to 150 lt

### PUMP FLOW RATE

from 1,6 lt to 41lt

#### DESCRIPTION

The CTR\* power units, are realised with a soaked gear pump and a vertically mounted electric motor.

The tank cover can be rotated of 180° without disassembling the installed components.

The standard components are intake filter, gear pump, motor - pump connection group, pressure relief valve, a position for one electro-valve (not included in the supplying), manometer with the shut-off cock, oil charge cover and oil visual indicator.

The electric motor supplied is a euro-tension 4-poles three-phase asynchronous motor with shape B5 according to UNEL-MEC standards.

The available paintings are dull black RAL 9005 (**standard**), Grey RAL 7037 and Green RAL 6011.

The power units works with mineral oil (not included in the supplying).

To work with other hydraulic fluids, please consult our Technical Department.

#### OPTIONAL COMPONENTS

The standard power unit can be equipped with the following components:

##### CTR 0 - 1 - 2

- other settings for electro-valves ISO 4401-03 (CETOP 03) with P2D modular subplates
- thermostat
- level gauge
- return filter for line mounting
- other colour paintings under request

##### CTR 3 - 4

- high pressure pumps H version
- other settings for electro-valves ISO 4401-03 (CETOP 03) with P2D modular subplates.
- thermostat
- level gauge
- a return filter for line mounting
- an heat exchanger air/oil or water/oil
- other colour paintings under request

The standard power unit is delivered without the functional diagram.

#### STANDARD COMPONENTS

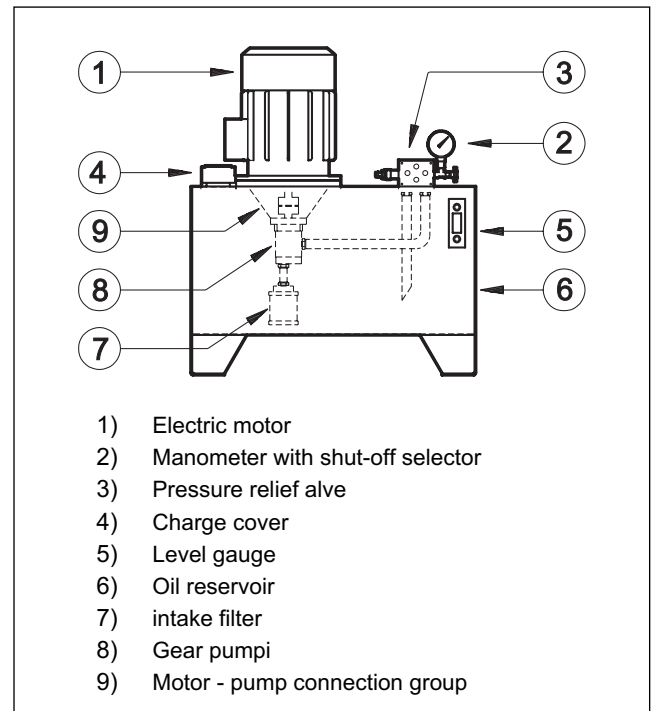

#### HYDRAULIC SYMBOL

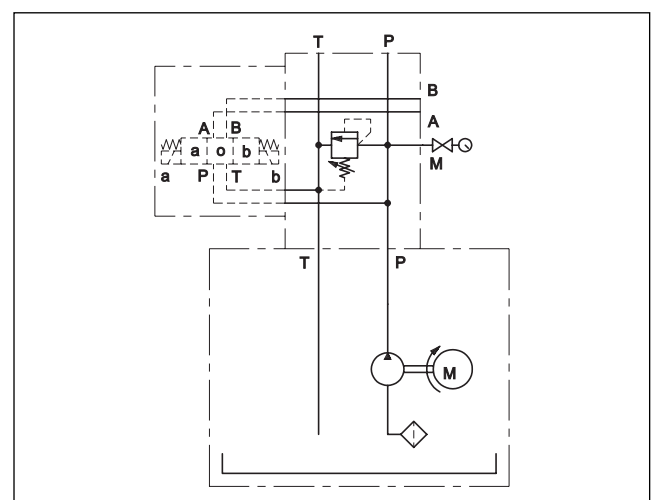





1.3 - Overall and mounting dimensions for CTR0

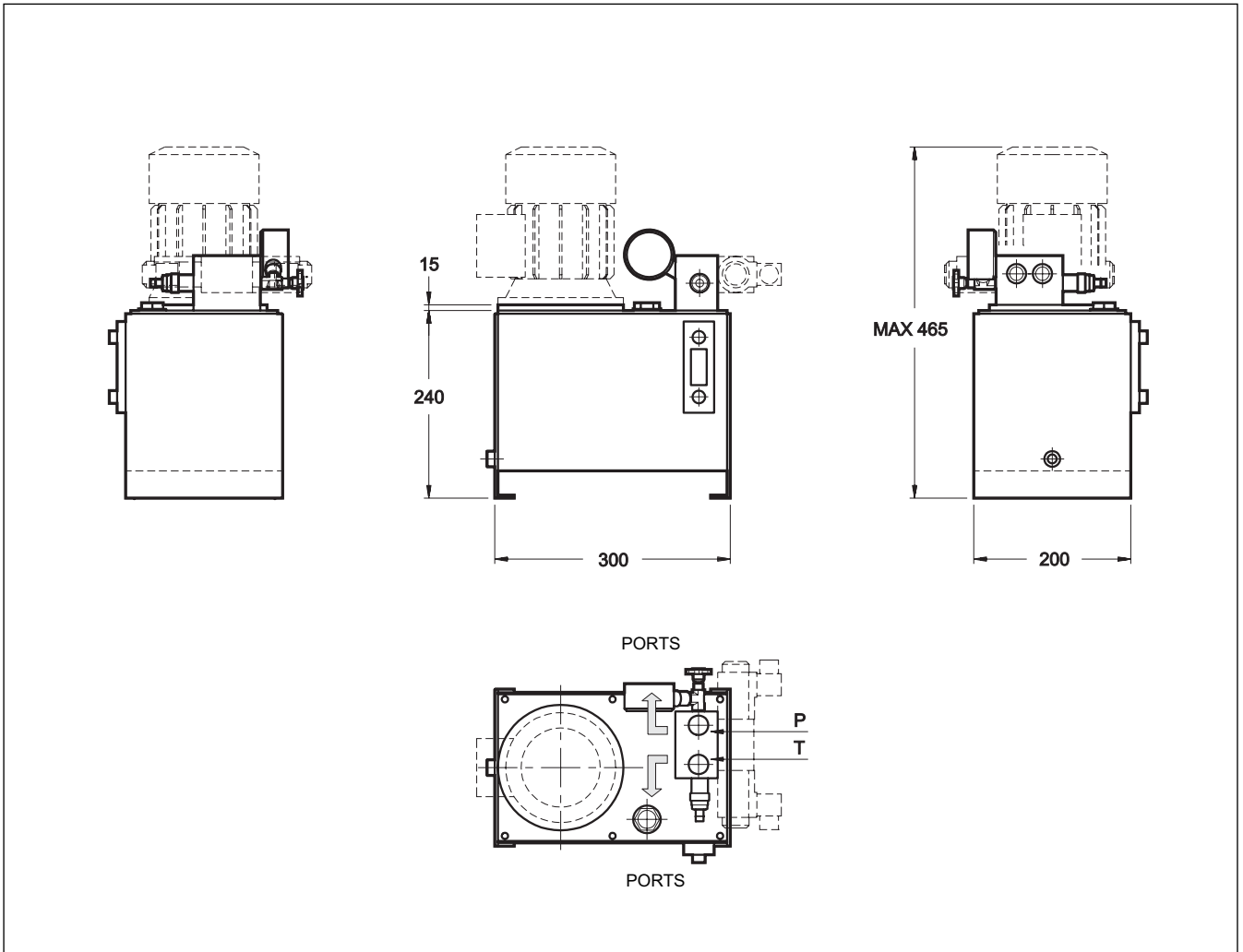



## 2 - POWER UNITS CTR1

### 2.1 - Identification code

<b>C</b>	<b>T</b>	<b>R</b>	<b>1</b>	<b>-</b>	<b>/</b>		<b>/</b>		<b>1P</b>	<b>-</b>	<b>/</b>						<b>/</b>	<b>40</b>
----------	----------	----------	----------	----------	----------	--	----------	--	-----------	----------	----------	--	--	--	--	--	----------	-----------

power unit with soaked pump

Cover size \_\_\_\_\_

Tank capacity \_\_\_\_\_  
**013** = 13 dm<sup>3</sup>  
**020** = 20 dm<sup>3</sup>

Electric motor B5 shape  
**P** = Predisposition for motor assembly  
**M** = Mounted electric motor

4-poles power electric motor: \_\_\_\_\_  
**0.55** = 0.55 kW  
**0.75** = 0.75 kW  
**1.1** = 1.1 kW  
**1.5** = 1.5 kW

Electric motor voltage (omit for P version)  
**A** = 230-400V / 50-60 Hz

Pump type **1P** \_\_\_\_\_  
 (see cat. 11 110 for the pump technical characteristics)

Flowrate pump (l/min) at 1500 rpm \_\_\_\_\_  
 (see flowrate / pressure table)

Series No. (from 40 to 49 sizes and mounting dimensions remain unchanged)

**N** = Dull black RAL 9005 (**standard**)  
**G** = Grey RAL 7037  
**V** = Green RAL 6011

Return filter:  
**0** = without filter  
**1** = filter with visual indicator  
**2** = filter with electric indicator

**0** = without thermostat  
**1** = with thermostat

**0** = without level gauge  
**1** = with level gauge

Standard panel with rear ports G 3/8"

**A** = P2D-M\* with 1 pos. ISO 4401-03 (CETOP 03)  
**B** = P2T-M\* with 2 pos. ISO 4401-03 (CETOP 03)

### 2.2 - Flowrate / pressure table

Electric motor flange size				Ø = 200			
CTR1		Pump type	Portata a 1500 giri/min [lt/min]	Electric motor power [kW]			
				0,55	0,75	1	1,5
				max pressure [bar]			
020	013	1P 1,6 R	1,6 *	180	-	-	-
		2 R	2,0	145	195	-	-
		2,5 R	2,4 *	120	160	-	-
		3,3 R	3,2	90	120	160	-
		4,2 R	3,9 *	75	100	130	200
		5 R	4,8	60	80	110	160
		5,8 R	5,5 *	50	70	95	140
		6,7 R	6,3	45	60	80	120
		7,5 R	7,1	40	55	70	110
			9,2 R	8,7 *	35	45	60
		11,5 R	11,9	25	30	45	65

\* pumps for preferential choice



## 2.3 - Overall and mounting dimensions for CTR1

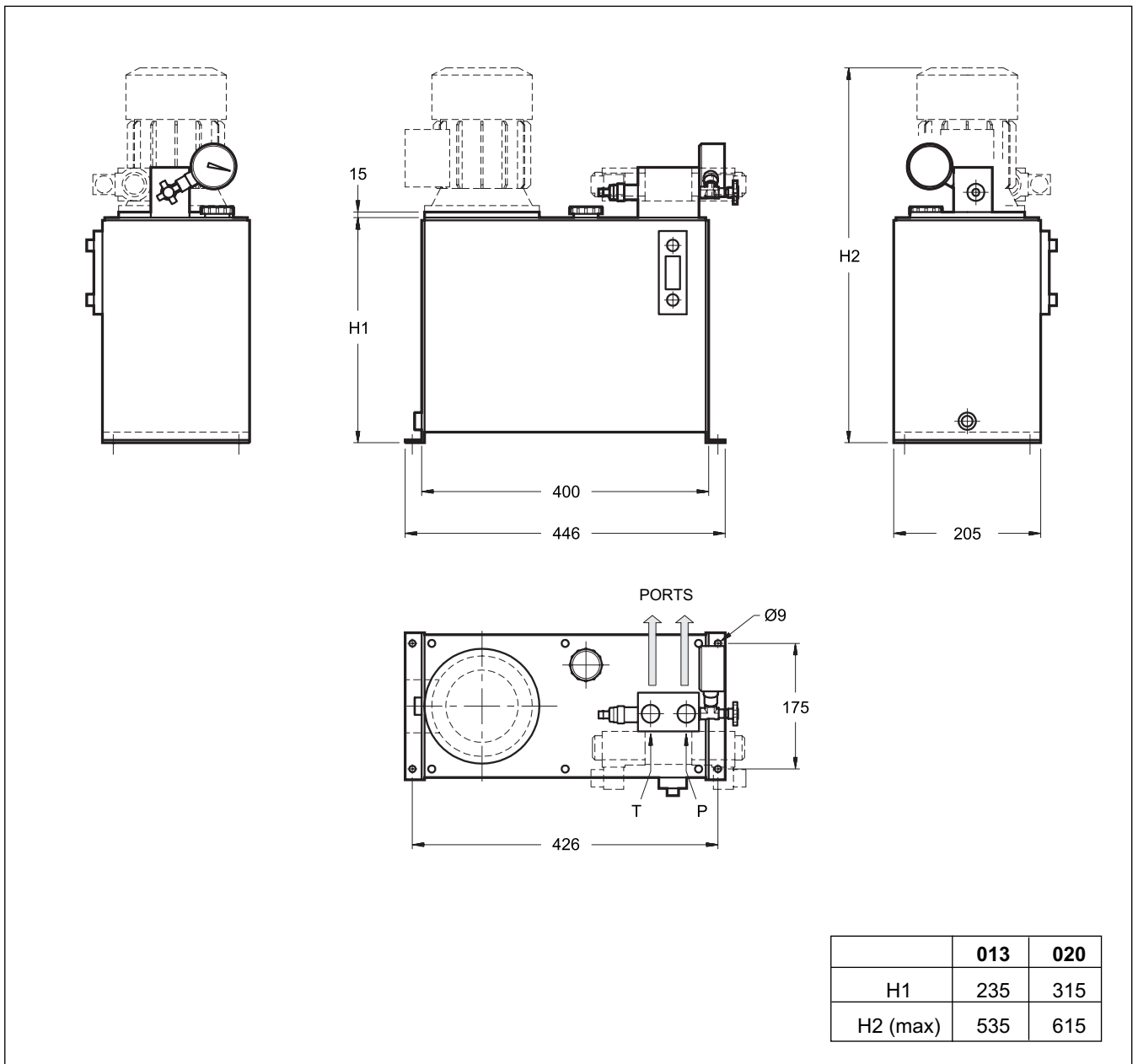





### 3.3 - Overall and mounting dimensions for basic CTR2

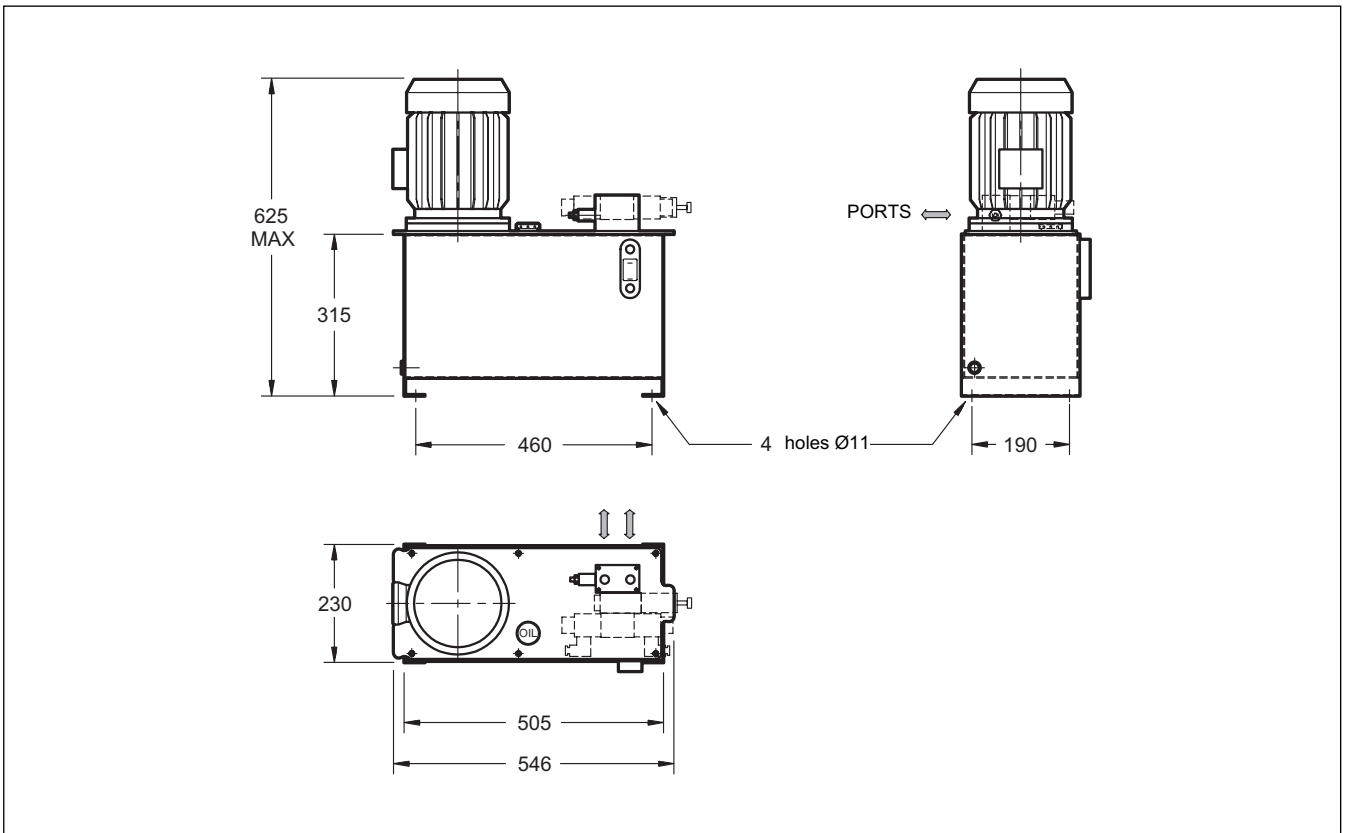

### 3.4 - CTR2 with optional

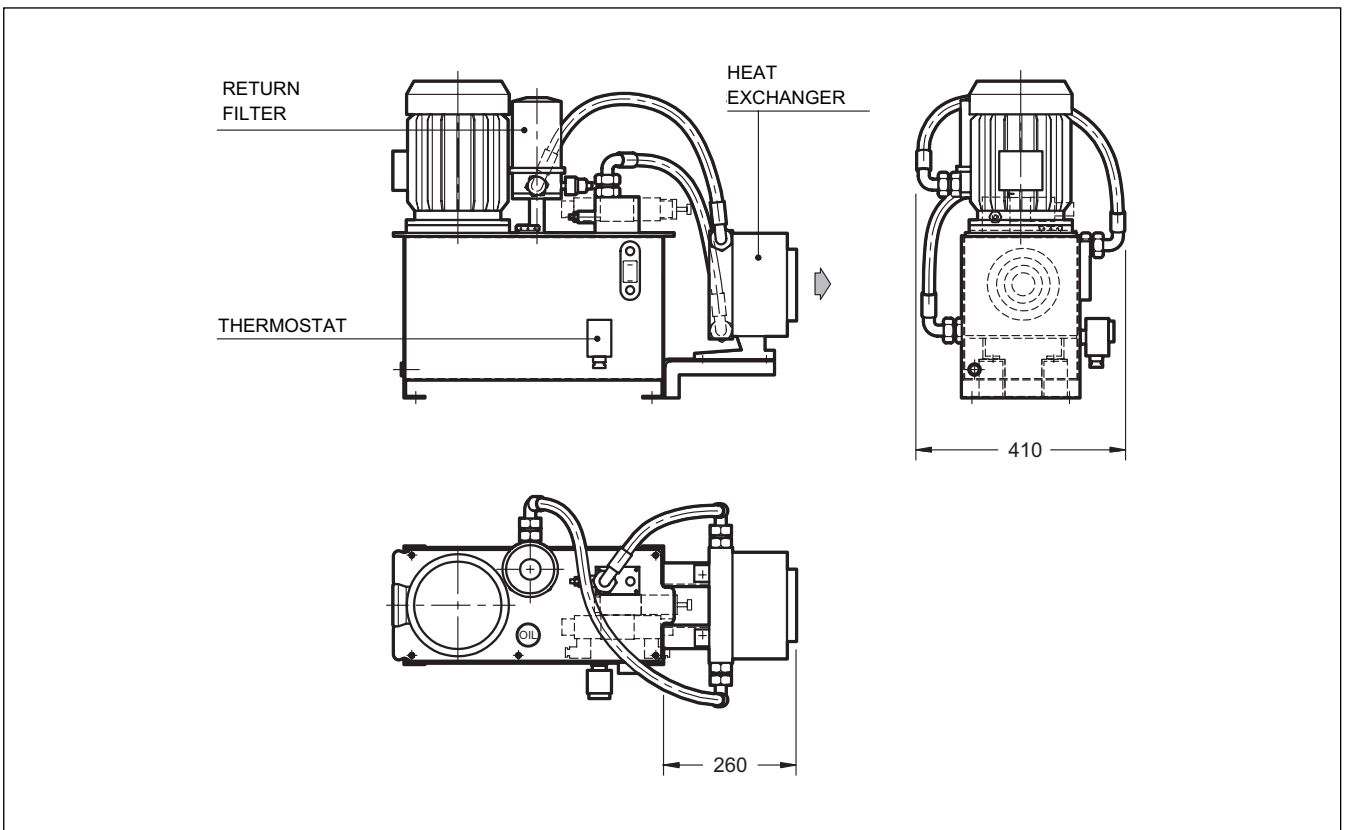





### 4.3 - Overall and mounting dimensions for basic CTR3

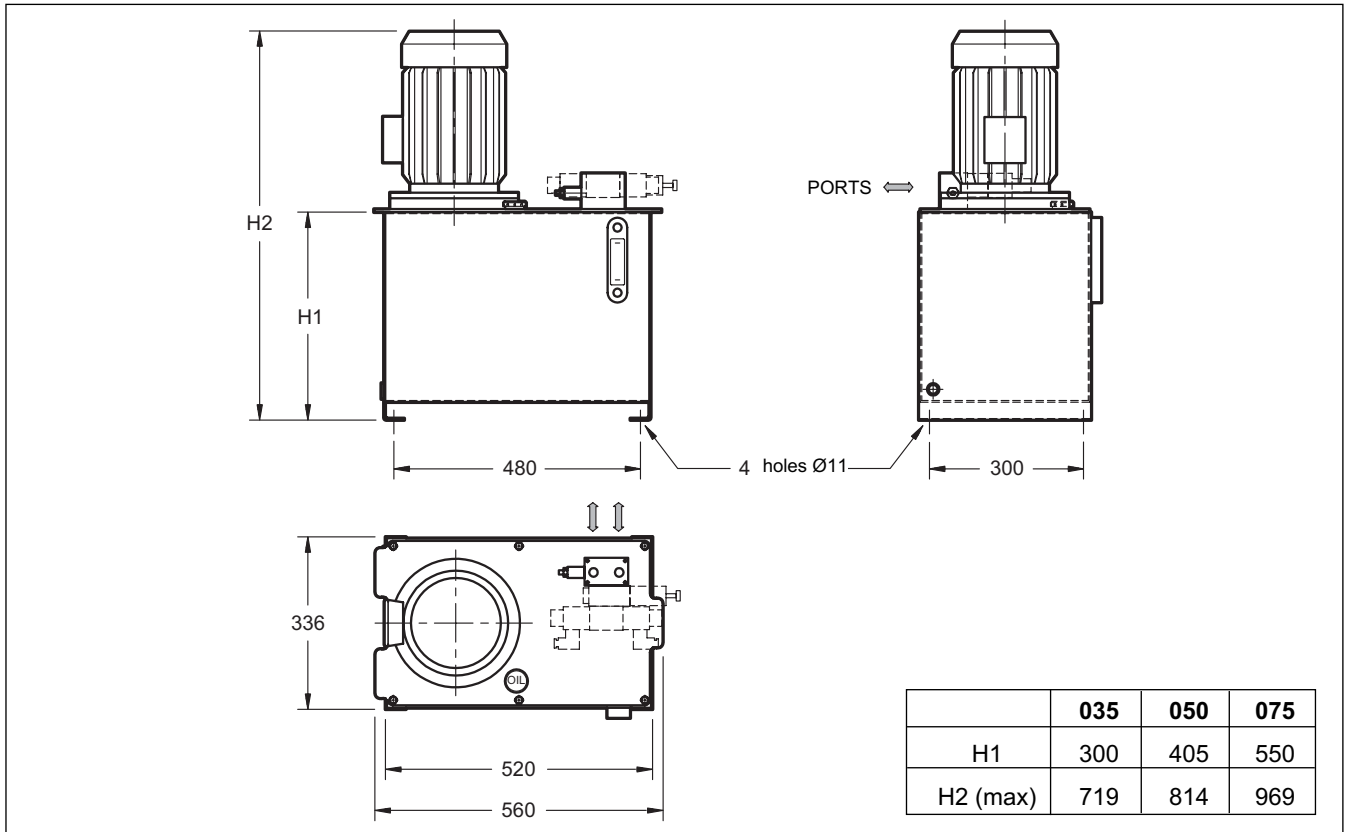

### 4.4 - CTR3 with optionals

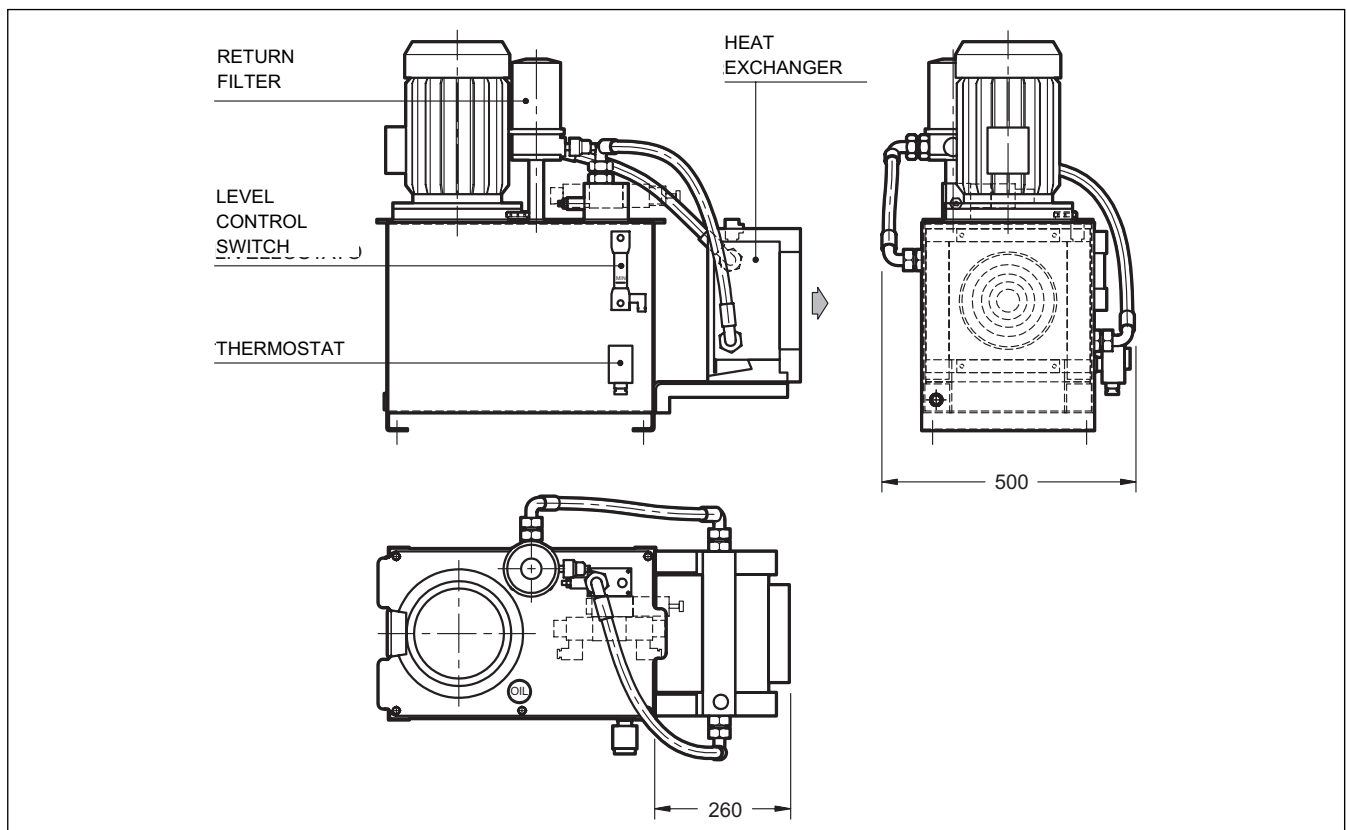





5.3 - Overall and mounting dimensions for CTR4-P2

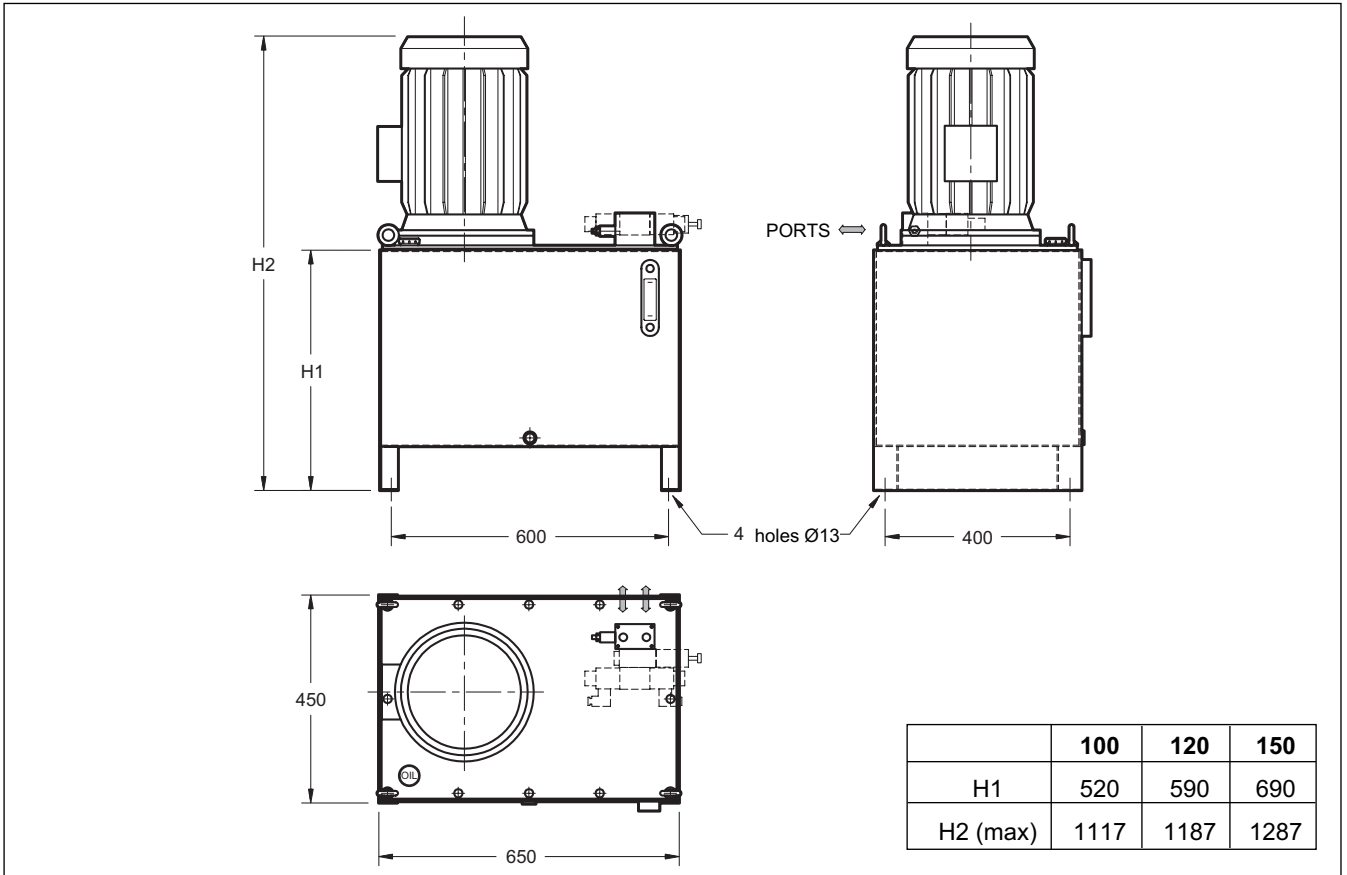

5.4 - Overall and mounting dimensions for CTR4-P2X\*M

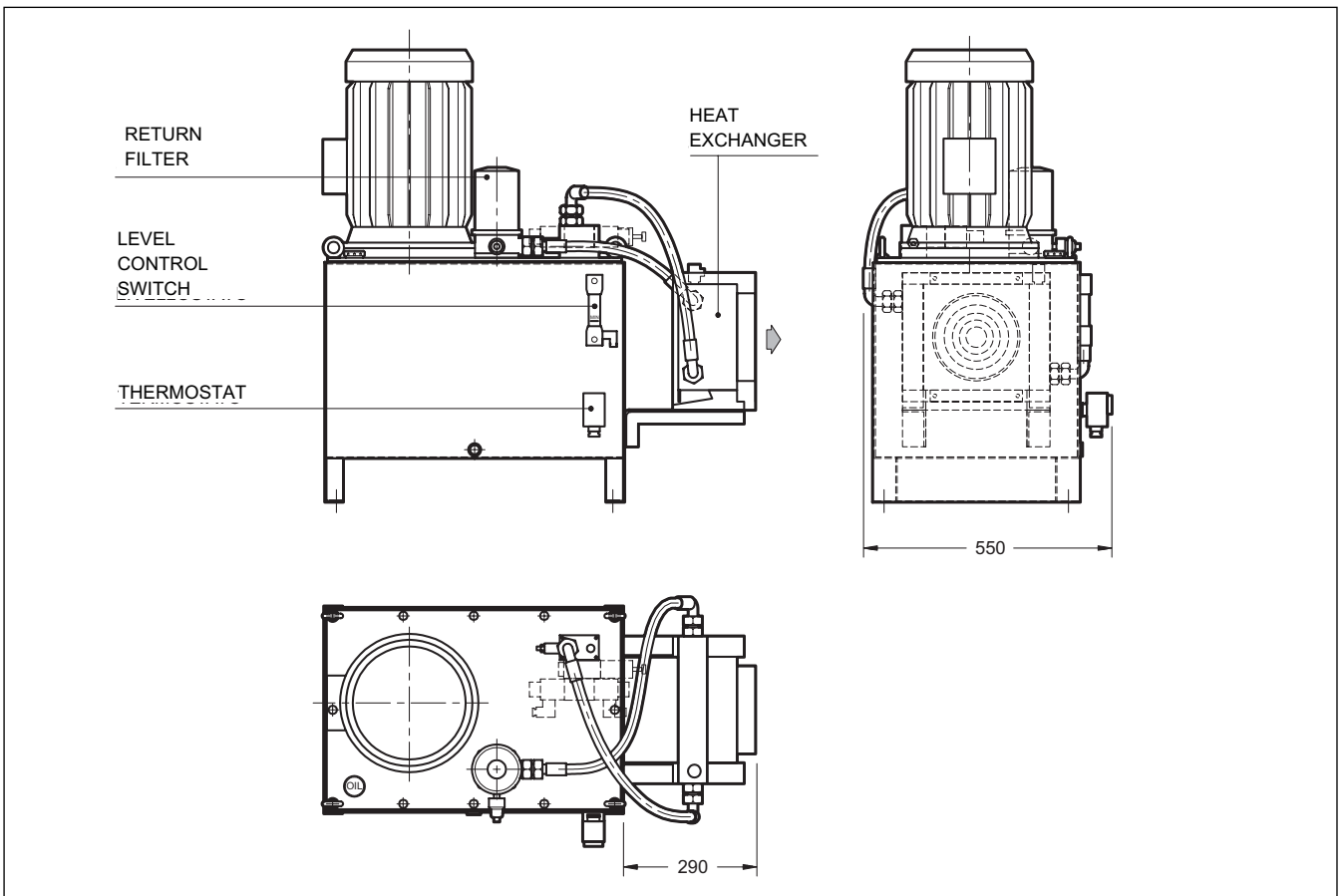



**6 - ACCESSORIES**

**6.1 - Level gauge LV/E1-127-M12-SC cod. 0770764**

Maximum pressure	bar	1
Working temperature	°C	-20 / +70
Transparent tube material	/	Nylon + glass 35%
Seals material	/	NBR
Reed in exchange	/	1A, 20W, 20VA, 200V

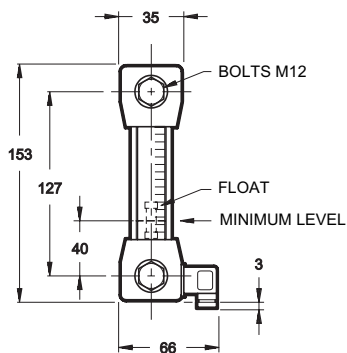
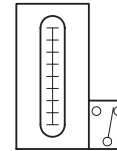

ELECTRIC DIAGRAM (WITH FLUID)

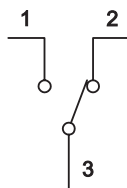

ELECTRIC DIAGRAM (WITHOUT FLUID)

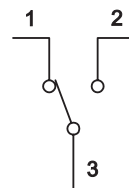

CONNECTOR CE DIN 40050 IP65 PG7

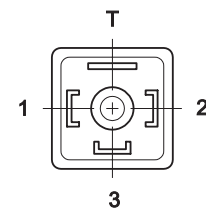

**6.2 - Thermostat TC2 cod. 0630285**

External sensor temperature range	°C	0/90
Degree of protection	/	IP40
Contacts	A	10
Max. voltage	V AC	250
Max. working temperature	°C	50
Cable guide	/	PG9
Housing material	/	Plastic
Contacts material	/	Silver
Capillary material	/	Copper
Pocket material	/	Brass
Mass	Kg	0.3

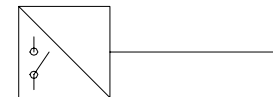

**6.2.1 - Overall dimensions**

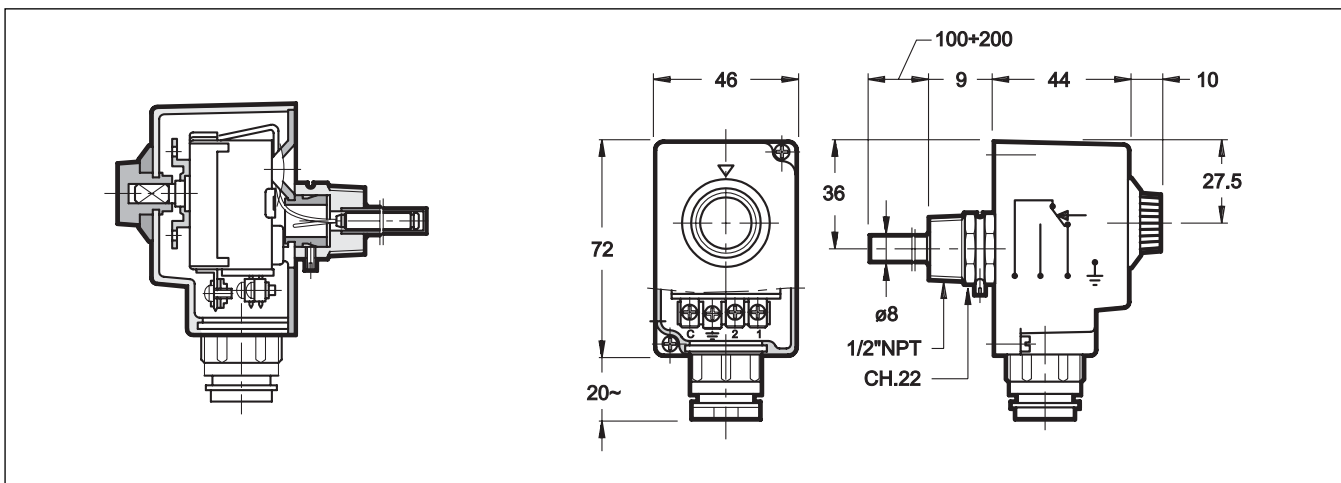



**6.3 - FRC return line filter for tank top or line mounting cod. 3951600004**

**6.3.1 - Technical data**

Filter code	BSP port dimensions	Mass [Kg]	Rated flow (indicative) [l/min] P25L
FRC-TB034	3/4"	1,6	75

**NOTE 1:** The flow rate stated in the table correspond to a 0.5 bar pressure drop measured with mineral oil of viscosity 36 cSt at 50°C.  
As for a different viscosity range, see the catalogue 95160.

Maximum pressure	bar	7
Collapsing differential pressure of the filter element	bar	3.0
Differential pressure for the opening of the by-pass valve ( $\pm 10\%$ )	bar	1,7
Ambient temperature range	°C	-25 / +50
Fluid temperature range	°C	-25 / +110
Fluid viscosity range	cSt	10 ÷ 400

For further detailed informations and overall dimensions please consult the catalogue 95160..

**6.3.2 - Clogging indicatorse**

The filters are all designed to incorporate clogging indicators, which have to be ordered separately.

**1 - VR/10 Visual indicator for return filters**  
**Identification code: 3959000003**

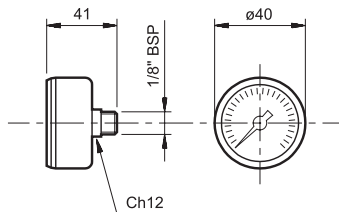

This indicator is a pressure gauge sensitive to the filter input pressure.

The indicator is supplied with a 0 ÷ 6 bar graduated scale and with a two-colour reading scale, which informs you about the clogging condition of the filter element:

- GREEN: efficient filter element (0 ÷ 1.7 bar)
- RED: the filter element has to be replaced (> 1.7 bar)

**2 - ER/10 Electric indicator for return filters**  
**Identification code: 3959000004**

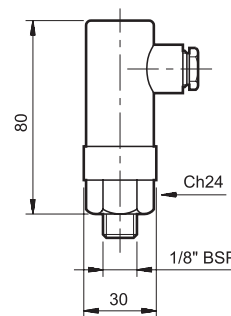

This indicator is a pressure switch sensitive to the filter input pressure, which switches an electric contact when the filter element has reached the clogging limit.

With an efficient filter, the contact is normally closed.

**TECHNICAL DATA**

Operating pressure	bar	1.5
Max operating voltage	V	220 50/60 Hz
Max load on the contacts:		
- resistive	A	0.5
- inductive		0.25
Max commutable power	VA	100
Protection class according to CEI EN 60529 (atmospheric agents)	IP65	



## 6.4 - Heat Exchanger oil/water with fixed blowing air flow .

### 6.4.1 - Technical data

		2010K	2020K
Code		0713268	0712078
Operating pressure	bar	20	
Test pressure	bar	35	
Maximum operating pressure	°C	120	
Air Flow	m <sup>3</sup> /h	190	645
Capacity	litre	0,3	0,7
Three-phase supply voltage	V	230 - 400	
Frequency	Hz	50 / 60	
Rpm	kW	0,045	0,068
Thermostat regulation field	°C	40 - 28	50 - 38
Oil threaded inlet / outlet connections	-	1/2" BSP	1" BSP
Mass	kg	6	8
IP protection degree		IP54	IP44

### CLEANING AND MAINTENANCE

As a general rule verify that the voltage supply correspond to those shown on the plate.

**Cleaning oil side:** The exchanger must be dismantled. Dirt can be removed by a detergent product as perchloride, in the opposite direction to normal. At the end it must be washed out with hot water.

**Cleaning air side:** This can be done means of compressed air or water. The direction of the jet must be parallel to the fins, to avoid damaging them. If the dirt is oil or greasy it must be cleaned by a jet of steam or hot water.

**The electric motor must be protected during the cleaning operation.**

### 6.4.2 - Characteristics

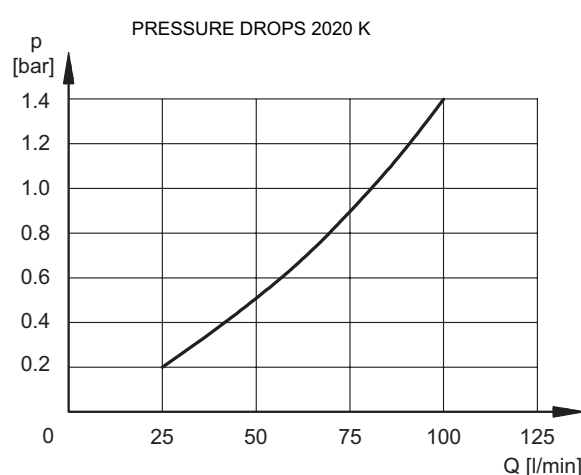
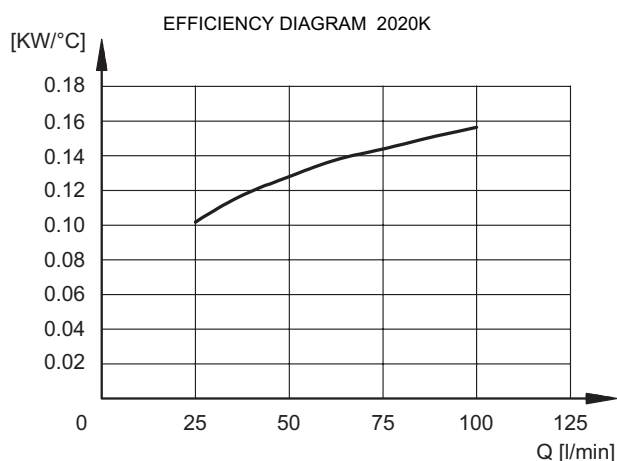
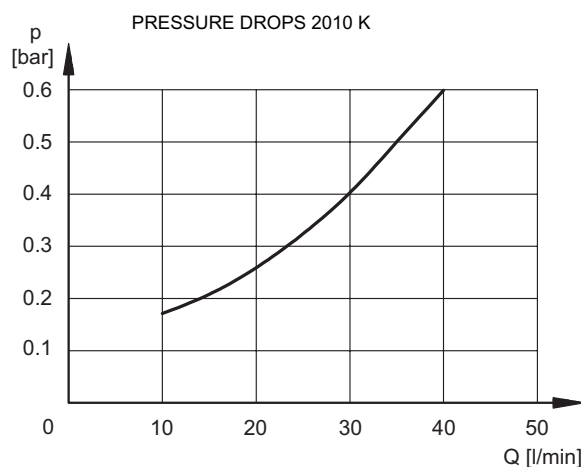
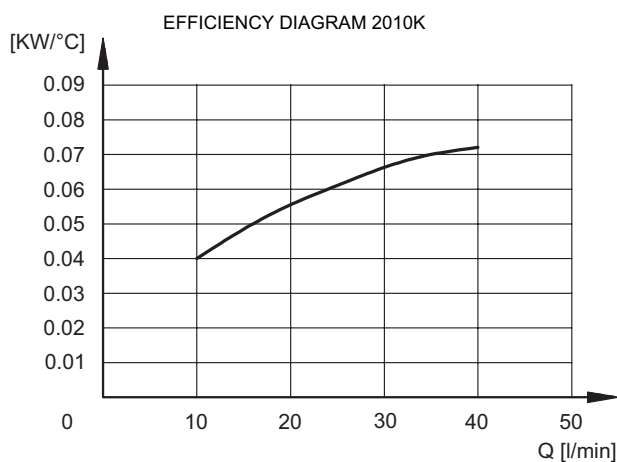



6.4.3 - Overall dimensions

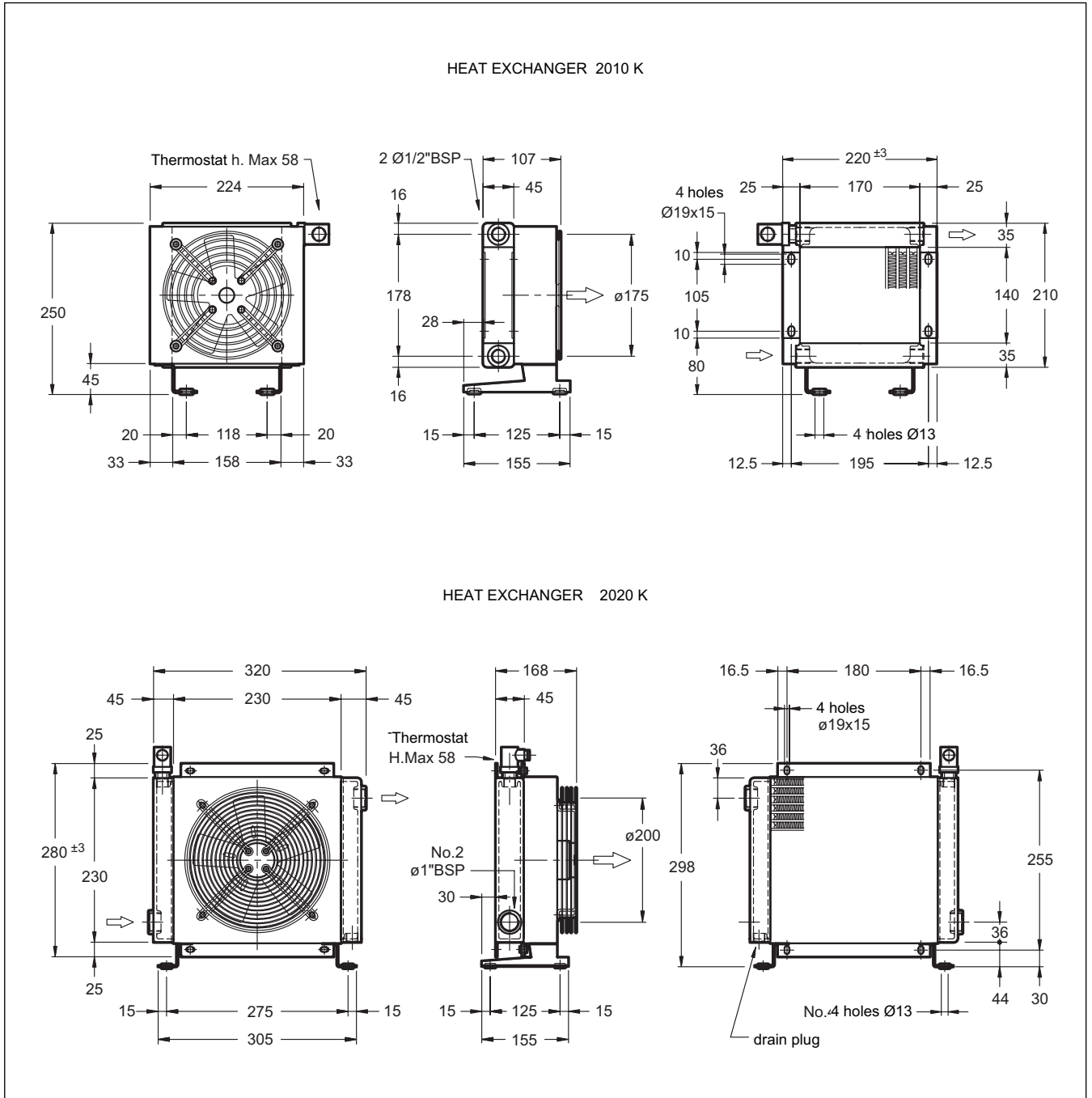



**CTR\***



**DIPLOMATIC  
HYDRAULICS**

**DIPLOMATIC OLEODINAMICA SpA**

20025 LEGNANO (MI) - P.le Bozzi, 1 / Via Edison  
Tel. 0331/472111 - Fax 0331/548328