

UEIK-1*

ELECTRONIC CONTROL UNIT FOR OPEN LOOP SINGLE SOLENOID PROPORTIONAL VALVE

SERIES 51

EUROCARD TYPE

FUNCTIONAL BLOCK DIAGRAM

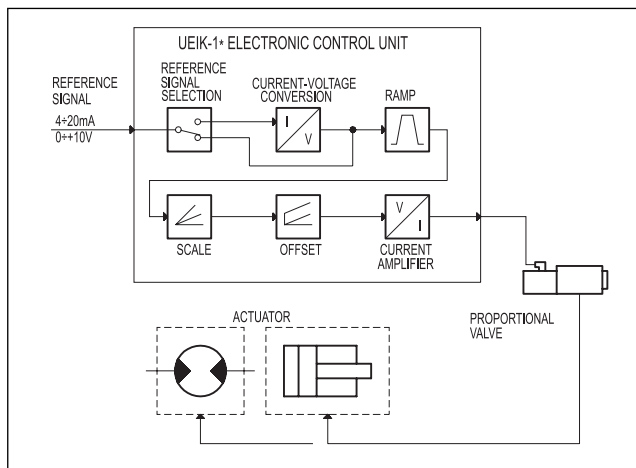

TECHNICAL CHARACTERISTICS

Power supply	V DC	22 ÷ 30 Ripple included
Required power	See par. 2.1	
Output current	See par. 3.3	
Power supply electrical protection	- overload - polarity inversion	
Reference signal: - Voltage - Current	V mA	0 / +10 4 ÷ 20
Input reference signal impedance: - Voltage - Current	kΩ Ω	10 250
Electromagnetic compatibility (EMC) - EMISSIONS EN 50081-1 - IMMUNITY EN 50082-2 (see par. 5 - NOTE 1)	in compliance with 89/336 EEC	
Card size	Eurocard 100x160x35	
Connector interface	DIN 41612-D 32 Male	
Operating temperature range	°C	0 ÷ 50
Mass	kg	0,20

FRONT PANEL

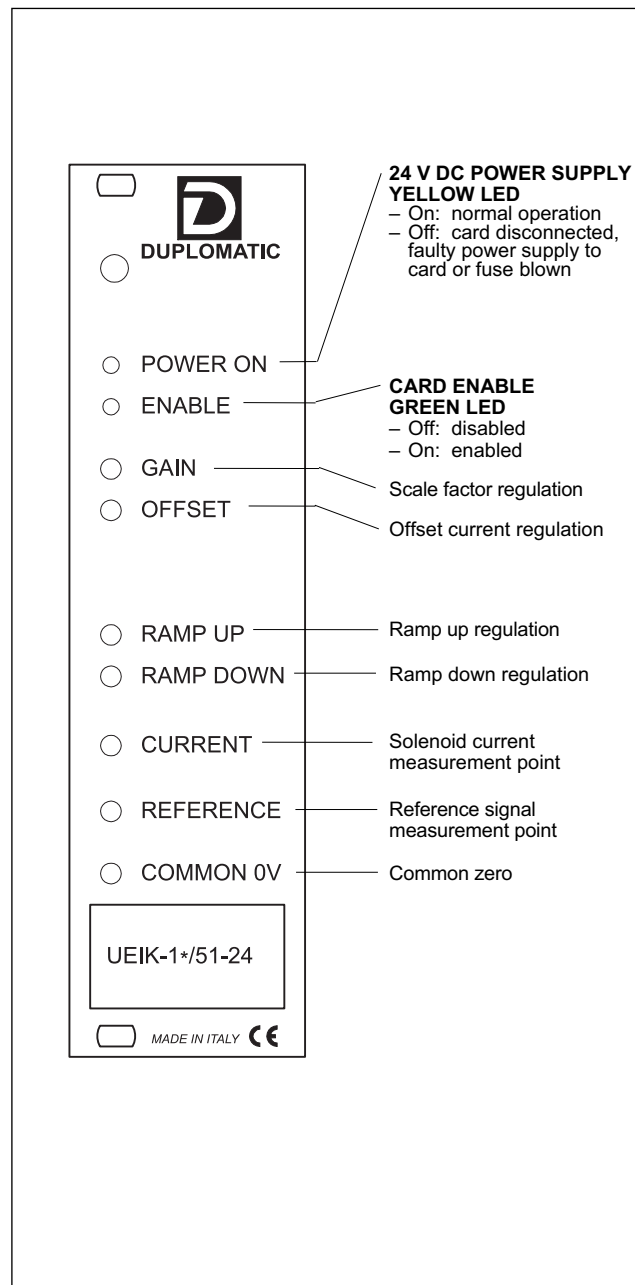



1 - IDENTIFICATION CODE

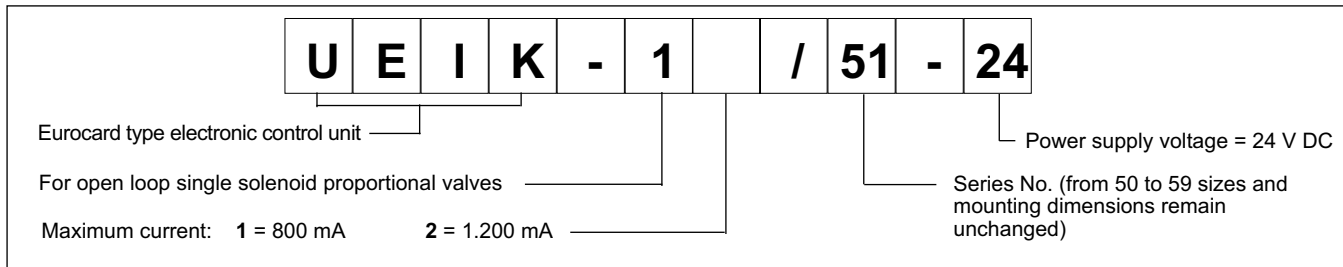

The UEIK-1* card is an electronic control unit Eurocard type for open loop single solenoid proportional valves.

The unit supplies a variable current in proportion to the reference signal and independently of temperature variations or load impedance.

The PWM stage on the solenoid power supply makes it possible to reduce valve hysteresis thus optimising control precision. The front panel is fitted with LEDs to indicate card functions and potentiometers to optimize control.

2 - FUNCTIONAL SPECIFICATIONS

2.1 - Electric power supply

The card requires a power supply of between 22 and 30 V DC (pin 2a/2c - 4a/4c) and a power of: 20W (UEIK-11) - 29W (UEIK-12). Power supply voltage must be rectified and filtered, with maximum admissible ripple within the above voltage range.

2.2 - Electrical protection

The card is protected against overvoltage and polarity inversion. A 2A fast-acting fuse is fitted for power circuit protection.

2.3 - Reference signal

The card accepts voltage reference signals (0 to +10V) or current reference signals (4÷20 mA).

N.B: If the signal is transmitted by potentiometer, please verify that this has a load of at least 200 Ω.

See para. 9 for electrical connections.

The diagram shows characteristics of current supplied according to the reference signal.

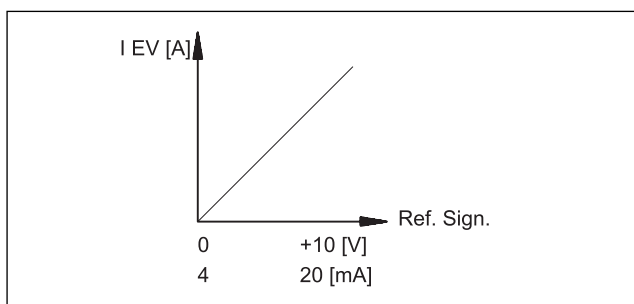

3 - SIGNALS AND ADJUSTMENT

3.1 - POWER ON

The green LED indicates card power supply:

ON - normal power supply

OFF - no power supply, faulty power supply or blown fuse

3.2 - ENABLE

A 22 to 30 V DC enable command on pin 24c is required for card operation.

The condition of the card enable is shown by both a visible LED on the front panel and as a contact available for the user on pins 6a and 6c.

The green LED indicates:

ON - card enabled

OFF - card disabled or failed

3.3 - GAIN (Scale factor regulation)

The "GAIN" potentiometer enables regulation of the relation between the set reference value and maximum current supplied to the solenoid and therefore the hydraulic parameter controlled by the valve.

The maximum current of the card is limited to 1,0A (UEIK-11) - 1,2A (UEIK-12). See par. 6 for default values.

Rotate clockwise to increase current.

3.4 - OFFSET (Offset current regulation)

The "OFFSET" potentiometer enables regulation of the offset current of the valve. It is used to eliminate the insensitivity zone (dead zone) of the valve.

The regulation field is from 0 to 0,5A (UEIK-11) - from 0 to 0,65A (UEIK-12).

The offset current is activated when the reference signal exceeds the threshold of + 150 mV (or 4,25 mA).

The offset is not active and only the polarization current equal to 25 mA is present beneath this threshold.

NOTE: The variation of the set value of the offset current causes a corresponding variation of the scale factor value.

Rotate clockwise to increase current.

3.5 - RAMP UP / RAMP DOWN (Ramp regulation)

"RAMP UP" and "RAMP DOWN" potentiometers, in a range from 0,03 to 7 sec., regulates the time required to reach the supplied current according to a step change of the reference signal up or down.

It is possible, in this way, to control the valve response time, adjusting it to the requirements of the hydraulic circuit and the machine cycle.

Ramps can be inhibited by transmitting a 22 to 30 V DC exclusion command to pin 16a. In this case, the ramp residual time is 10 ms.

Rotate clockwise to increase ramp time.



4 - SIGNAL MEASUREMENT

4.1 - CURRENT (Solenoid current measurement point)

Enables voltage reading of current supplied to the solenoid.

Reading conversion: 1V DC = 1A (UEIK-11)

0,82V DC = 1A (UEIK-12).

4.2 - REFERENCE (Reference signal measurement point)

Enables reading in voltage of reference signal sent to the card.

Reading is direct, but of opposite sign, with voltage reference while

current conversion is: 4 mA = 0 V 20 mA = - 10V.

5 - INSTALLATION

The card is suitable for assembly on a rack or a card holder with interface for connector types DIN 41612 - size D - 32 pole.

It is recommended to use cable sections of 1 to 2,5 mm², depending on their length, for power supply and solenoid connections. For other connections it is recommended to use cables with a screened sheath connected to earth only on the card side.

NOTE 1: To observe EMC requirements it is important that the control unit electrical connection is in strict compliance with the wiring diagram of par. 9.

As a general rule, the valve and the electronic unit connection wires must be kept as far as possible from interference sources (e.g. power wires, electric motors, inverters and electrical switches).

In environments that are critical from the electromagnetic interference point of view, a complete protection of the connection wires can be requested.

6 - DEFAULT CONDITIONS

The electronic unit is supplied factory set.

The setting conditions are:

- "GAIN" regulation: +10V (or 20 mA) reference signal corresponding to a current supply of 0,7 A to the solenoid.
- "OFFSET" regulation: zero
- "RAMP UP" and "RAMP DOWN" regulation: minimum
- position SW1 on V
- position SW2 on S
- position SW3 on AA
- switching frequency (PWM) = 200Hz (UEIK-11)
100Hz (UEIK-12).

7 - START-UP AND CONTROL SETTINGS

If required, it is possible to change the settings as follows:

a) OFFSET CURRENT ADJUSTMENT

- Set "GAIN" potentiometer to minimum.
- Enter reference signal at maximum value (+10V or 20 mA).
- Set the "OFFSET" potentiometer so that the valve is positioned at the start of the work zone.

b) SCALE FACTOR ADJUSTMENT

- Enter the reference signal at maximum value (+10V or 20 mA).
- Set "GAIN" potentiometer so that the controlled hydraulic parameter reaches the maximum required value.

NOTE: The maximum current value must be compatible with the maximum current prescribed by the technical table of the connected proportional valve.

c) RAMP REGULATION

- Regulate the "RAMP UP" and "RAMP DOWN" potentiometers to obtain gradual valve operation required with a reference signal variation.

8 - CARD CIRCUIT SETTINGS

The overall and mounting dimensions diagram in par. 10 shows three switch banks: SW 1 - SW 2 - SW 3 which enable the card to be set up as required.

NOTE: Each modification to switch settings must be carried out with the card disconnected from the power supply. The individual switches inside each bank must all be set in the same position.

SELECTION OF VOLTAGE OR CURRENT REFERENCE SIGNAL (SW 1 bank comprising three individual switches)

- select V for voltage reference signal
- select I for current reference signal.

SELECTION OF SINGLE ENDED OR DIFFERENTIAL REFERENCE SIGNAL (SW 2 bank comprising one individual switch)

- select S for single ended reference signal. This condition is obligatory in the case where the reference signal is generated with an external potentiometer fed by the card itself.
- select D for differential reference signal. This condition is preferable in the case where the reference signal comes from a PLC or CNC analogic outlet.

NOTE: The SW 3 bank, comprising two individual switches, must always be set at AA as per standard default conditions.

SWITCHING FREQUENCY ADJUSTMENT

It is possible to change the switching frequency (PWM) by acting on the trimmer PT7 (see par. 10).

The setting range is from 80 to 370 Hz.

An appropriate switching frequency adjustment allows reduction of the valve hysteresis value.

Clockwise rotation to increase the frequency.



9 - CARD CIRCUIT AND WIRING DIAGRAMS

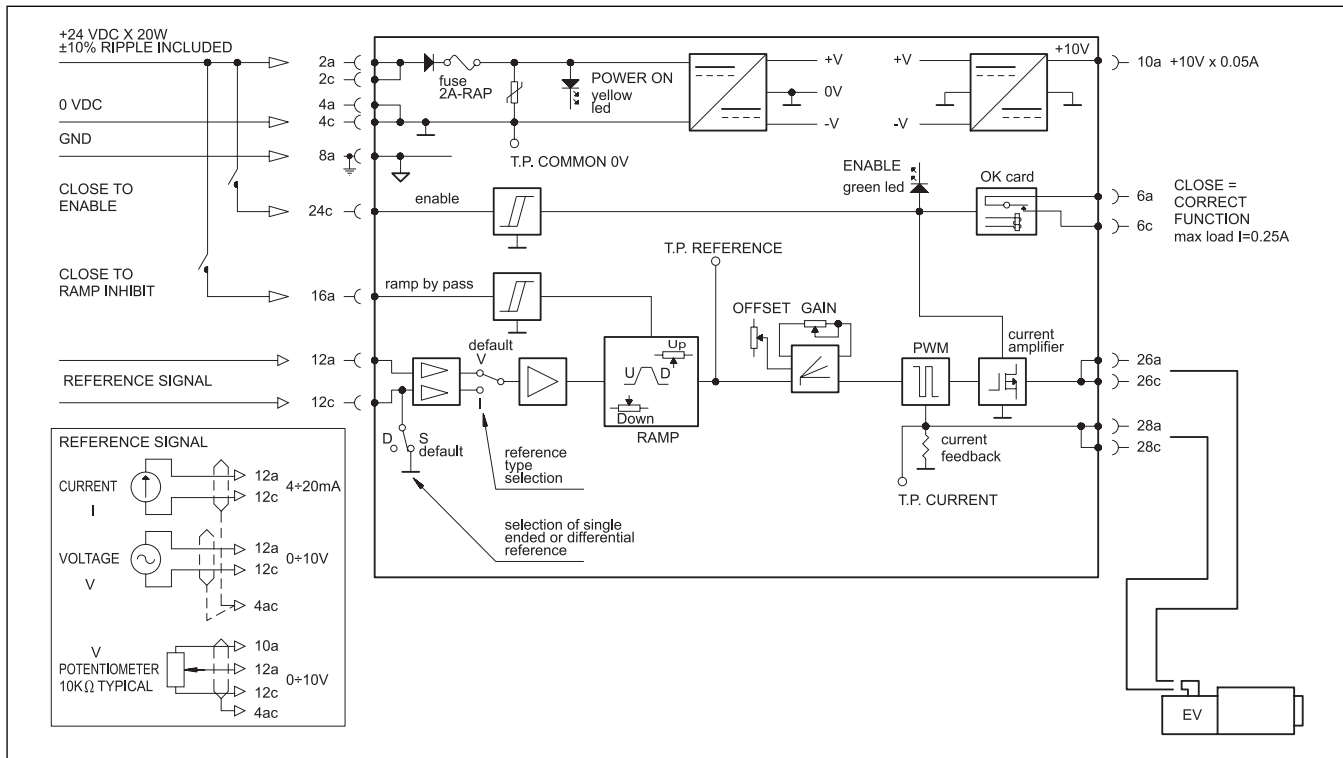

10 - OVERALL AND MOUNTING DIMENSIONS

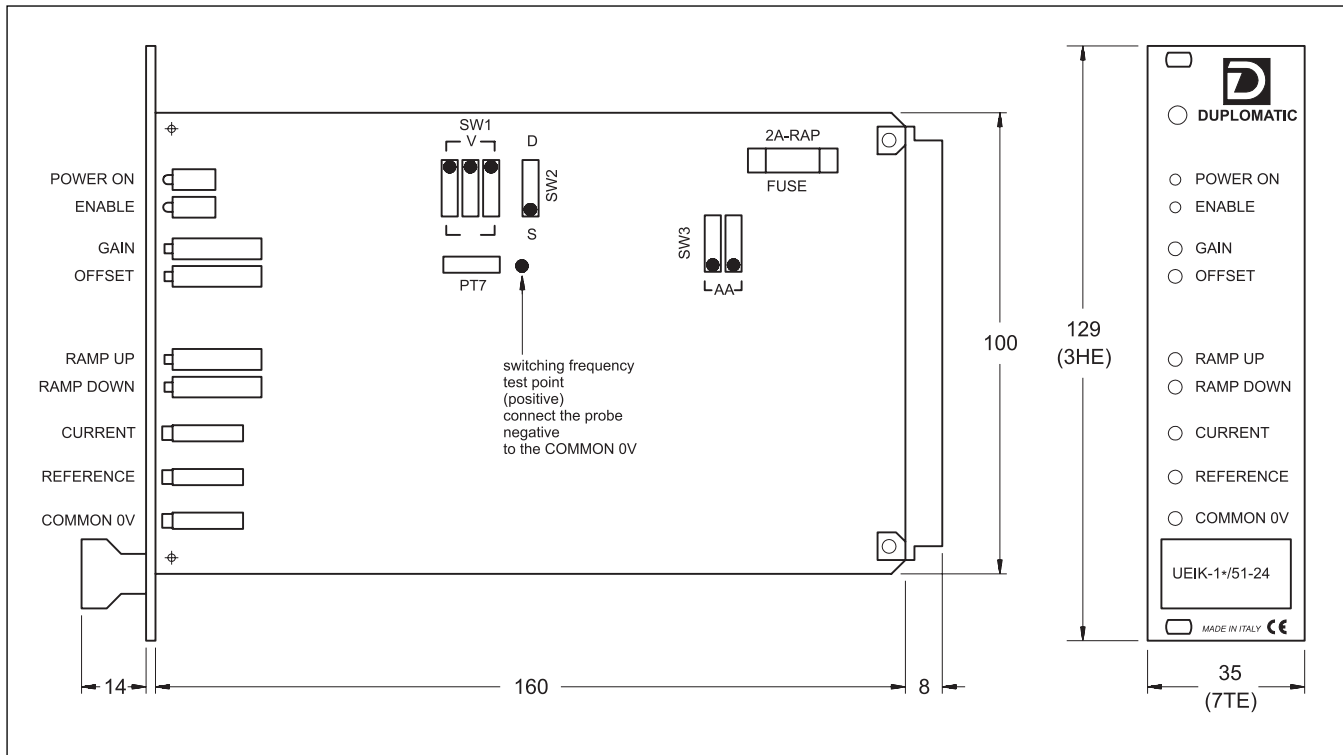

DIPLOMATIC
HYDRAULICS

DIPLOMATIC OLEODINAMICA SpA

20025 LEGNANO (MI) - P.le Bozzi, 1 / Via Edison
Tel. 0331/472111-472236 - Fax 0331/548328