

# EPR-P1\*

## POWER AMPLIFIER FOR PRESSURE FEEDBACK PROPORTIONAL VALVES

### SERIES 11

**EPR-P1\*** single solenoid pressure feedback

**RAIL MOUNTING TYPE:  
DIN EN 50022**

The card EPR-P1\* is a power amplifier controlling closed loop proportional valves. It is designed for rail mounting types: DIN EN 50022.

The card EPR-P1\* enables a pressure control, which creates a direct and linear correspondence between the reference signal and the regulated pressure.

The card is available with different maximum current settings and switching frequencies (PWM), optimized according to the valve to be controlled. On the front panel there are regulations for the performances optimisation.

#### SPECIFICATIONS

Power supply	V DC	10 ÷ 30 Ripple included
Required power	see parag. 3.1	
Output current	see parag. 1.2 and 10	
Power supply electrical protections	– overload – polarity inversion	
Output electrical protections	Short circuit	
Reference signal	See parag. 3.3	
Feedback signal	See parag. 3.4	
Output signal	See parag. 3.5	
Input reference signal impedance	kΩ	100
Electromagnetic compatibility (EMC) - EMISSIONS - IMMUNITY (see parag. 5)	EN 50081-1 EN 50082-1	
Housing material	thermoplastic polyamid	
Housing dimensions	mm	120 x 93 x 23
Connector	Plug-in terminal block tightening screws N. 15 poles	
Operating temperature range	°C	-20 / +70
Mass	kg	0,15

#### FUNCTIONAL BLOCK DIAGRAM

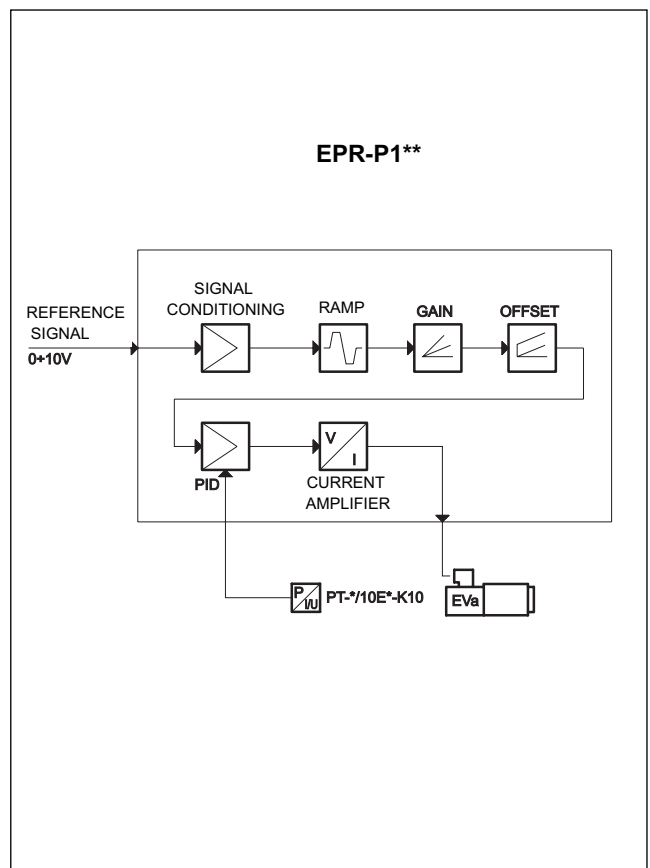



# EPR-P1\*

## SERIES 11

### 1 - IDENTIFICATION CODE FOR CARDS WITH CLOSED LOOP FUNCTIONING

E	P	R	-	P1			/	11	E0
---	---	---	---	----	--	--	---	----	----

Power amplifier  
for position feedback valves  
Modular version for rail mounting type DIN EN 50022

Versions: \_\_\_\_\_  
**P1** = for single solenoid proportional valves with pressure feedback

CLOSED LOOP: progressive number which identifies the valve to witch the card is matched, according to the following table:

Number	Valve	Frefuence (Hz)
<b>52</b>	RQE	400
<b>53</b>	CDE	400
<b>54</b>	MZE	400

Reference signal with voltage:  
0 ÷ 10V

Series No. (from 10 to 19 mounting  
dimensions and wiring diagrams  
remain unchanged)

### 2 - IDENTIFICATION CODE FOR CARDS WITH OPEN LOOP FUNCTIONING

E	P	R	-	P1			/	11	E0
---	---	---	---	----	--	--	---	----	----

Power amplifier  
for position feedback valves  
Modular version for rail mounting type DIN EN 50022

Versions: \_\_\_\_\_  
**P1** = for single solenoid proportional valves for pressure control

OPEN LOOP: Maximum current  
**1** = 800 mA      **3** = 1600 mA  
**2** = 1200 mA    **4** = 2000 mA

Reference signal with voltage:  
0 ÷ 10V

Series No. (from 10 to 19 mounting  
dimensions and wiring diagrams  
remain unchanged)

OPEN LOOP: Switching frequency  
**0** = 200 Hz  
**1** = 100 Hz  
**4** = 400 Hz

N.B.: this version can be used to drive proportional valves without position feedback as an alternative to the standard card EPA for applications in which a different setting of the ramp value between rise and descent is needed. It also allows to supply possible external potentiometers with the virtual zero.



## 3 - FUNCTIONAL SPECIFICATIONS

### 3.1 - Electric power supply

The card requires a power supply of between 10 and 30 VDC (terminals 1 and 2).

NOTE: The value of the power supply voltage on the card must not be lower than the rated working voltage of the solenoid to be controlled.

The power supply voltage must be rectified and filtered, with maximum admissible ripple within the above voltage range.

The power required by the card depends on the power supply voltage and on the maximum value of the supplied current (it is determined by the card version). In general a conservative value of the required power can be considered as the product of  $V \times I \times \eta$ , where  $V$  is the power supply,  $I$  the maximum value of the current supplied to the solenoid and  $\eta$  is the efficiency, that for this card type is up to 80%.

Example: a card with a maximum current = 800 mA and a power supply voltage of 24 VDC requires a power of about

$$P = 24 \times 0.800 / 0.8 = 24W$$

In case of a card with a maximum current = 1600 mA and a power supply voltage of 24 VDC the used power is equal to

$$P = 24 \times 1.600 / 0.8 = 48W$$

In case in which the card is used to supply an external transducer pay attention that the power supply voltage is equal to the one required by the transducer.

### 3.2 - Electrical protections

The card is protected against overvoltage and polarity inversion. On the output a protection against any short circuit is foreseen.

### 3.3 - Reference signal

The card accepts voltage reference signals from an external generator (PLC or CNC with standard output 0 ÷ 10V) or from a potentiometer power supplied by the card itself. See par. 8, 11 for the electric connections referring to the different card versions.

### 3.4 - Feedback

The card is designed in order to receive a feedback signal coming from a pressure transmitter which gives a signal of 4 ÷ 20 mA, or of 0 ÷ 10V.

#### 3.4.1 - Use with open loop

If the functioning of the hydraulic system needs it, it is possible to change the feedback with an open loop control. This change will modify the position of SW6

### 3.5 - Output signals

By using the selector SW4 it is possible to choose the output signal type: an analogic signal which is proportional to the effective pressure or an on-off type output signal which indicates if the effective pressure is included between the range of  $\pm 3\%$  of the settled pressure. The on-off signal has an output type "open collector"; see par. 8, 11 for the wiring. The analogic signal is parametrized to maximum pressure settled during the start up (par. 9) and it must be readreferring to the clamp 14. Stated that  $P_{max}$  is the maximum settled pressure, the relationship between the present pressure and the voltage on the clamp 12 (between 0 and -2V) is the following:

$$P = - \frac{P_{max}}{2} \times V$$

## 4 - SIGNAL AND ADJUSTMENT

### 4.1 - Power ON (Power supply)

The green LED indicates the card power supply:

ON - normal power supply

OFF - no power supply or protection interrupted

### 4.2 - RAMP UP / RAMP DOWN (Ramp regulation)

The trimmers RAMP UP and RAMP DOWN regulate the time required to reach the current according to a step change of the reference signal. Regulation is the same for increases or decreases in the reference signal. The selector SW1 inside the card permits to select two different ramp time regulation ranges:

- selector SW1 in position 2-3 = adjustable time from 0 to 5 sec.

- selector SW1 in position 1-2 = adjustable time from 0 to 1 sec (default condition).

This makes it possible to control the valve response and adapt it to the requirements of the hydraulic system and the machine cycles. Rotate clockwise to increase ramp time.

### 4.3 - OFFSET (Offset current regulation)

The OFFSET A trimmer enables the regulation of the offset current. It is used to eliminate the valve insensitivity zone (dead band). The offset current is always active, independently from the reference. Notice that with pressure closed loop the offset current becomes the minimum pressure.

### 4.4 - GAIN (Scale factor regulation)

The GAIN A trimmer enables regulation of the ratio between the set reference value and the maximum current supplied by the card. Therefore an independent regulation of the controlled parameters for each of the valve hydraulics configurations is possible. The setting range goes from zero to 100% of the full scale value. Multiturn trimmers - Rotate clockwise to increase current.

NOTE: The card maximum current is limited by the LIMIT A internal trimmer according to the card version (see par. 4.6). See par. 10 for the default value.

### 4.5 - SWITCHING (PWM frequency regulation)

This trimmer adjusts the switching frequency (PWM). The setting range goes from 50 ÷ 450 Hz. An appropriate switching frequency adjustment allows a reduction of the valve hysteresis value. Single turn trimmer - Rotate clockwise to increase frequency.

NOTE: The potentiometer setting is sealed with a red coating and it must never be adjusted by the user.

### 4.6 - LIMIT

The setting of these two potentiometers states the maximum current supplied by the card. Different settings of the current maximum value refer to different card versions.

### 4.7 - OFFSET TR (Transmitter offset regulation)

It allows the zero setting of the transmitter output signal when there is no pressure in the hydraulic system.

### 4.8 - GAIN TR (Transmitter gain regulation)

It allows the regulation of the transmitter gain, that conforms the transmitter output signal to the nominal pressure regulated by the valve.

### 4.9 - DAMPING (Dynamic response regulation)

It allows the regulation of the valve dynamic quickness so as it can follow the settled pressure value.



## 5 - INSTALLATION

The card is designed for rail mounting type DIN EN 50022. The wiring connections are on the terminal strip located on the bottom of the electronic control unit. It is recommended to use cable sections of 1 to 2.5 mm<sup>2</sup>, depending on their length, for power supply and solenoid connections. For other connections it is recommended to use cables with a screened sheath connected to earth only on the card side.

**NOTE** To observe EMC requirements it is important that the control unit electrical connection is in strict compliance with the wiring diagram of par. 8 - 11 of this catalogue.

As a general rule, the valve and the electronic unit connection wires must be kept as far as possible from interference sources (e.g. power wires, electric motors, inverters and electrical switches).

In environments that are critical from the electromagnetic interference point of view, a complete protection of the connection wires can be requested.

## 6 - SIGNAL MEASUREMENT

The EPA-TC/20 device (to be ordered separately) has the test points facilities for current, feedback and reference signal reading. This device has to be connected, by means of a flat cable, to the interface placed on the EPR card front side, behind the protecting gate.

### 6.1 - Reference measurement

The test point REF.A enables reading in voltage of reference signal sent to the EPR card.

Reading is of opposite sign and divided by 5 as regards to the reference signal.

Reading conversion is  $-1V \text{ (measured)} = +5V \text{ (reference)}$ .

### 6.2 - Feedback measurement

The test point REF.B enables reading in voltage of the trimmer return signal; the use of this test point is explained in the par.9 related to the start up.

### 6.3 - Currents measurement

The test points I.A and I.B enable measurement in voltage of current supplied to solenoids A and B of the valve.

Reading conversion is  $0,5V = 1A$ .

**NOTE:** The points COM-R and COM-I must never be connected between themselves.



## 7 - DEVICE FOR SIGNAL READING EPA-TC/20 (to be ordered separately)

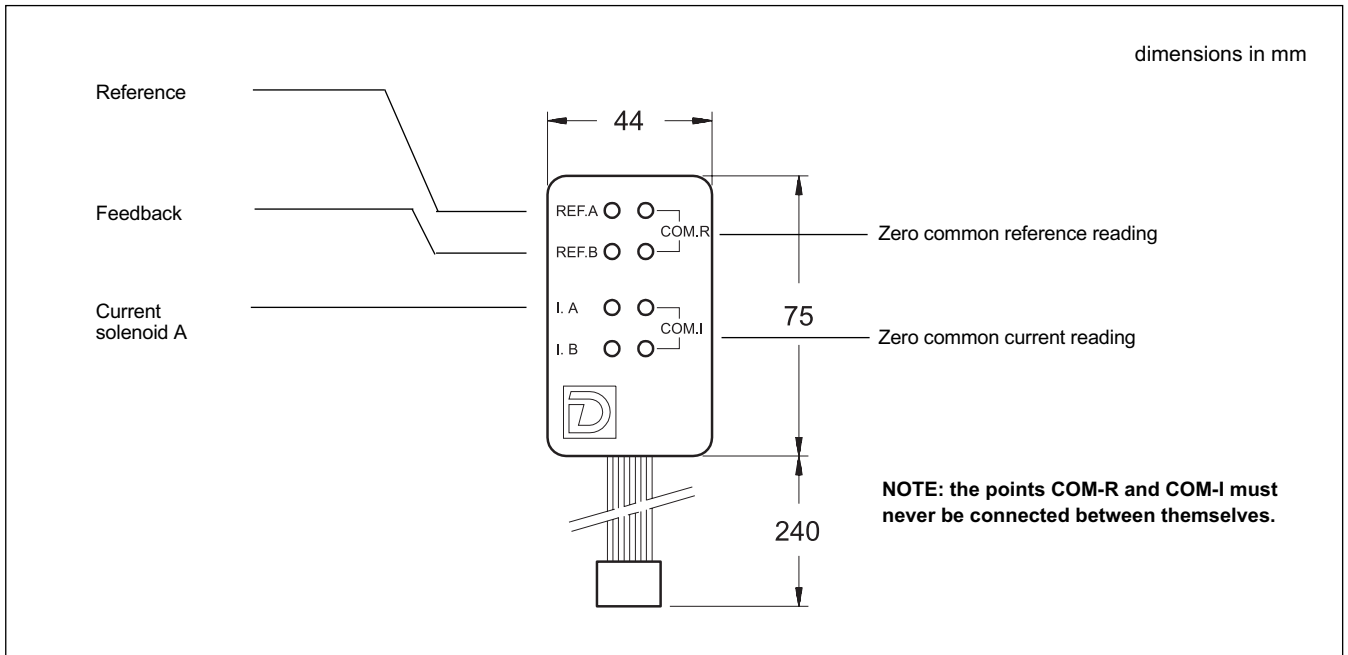

## 8 - WIRING DIAGRAM

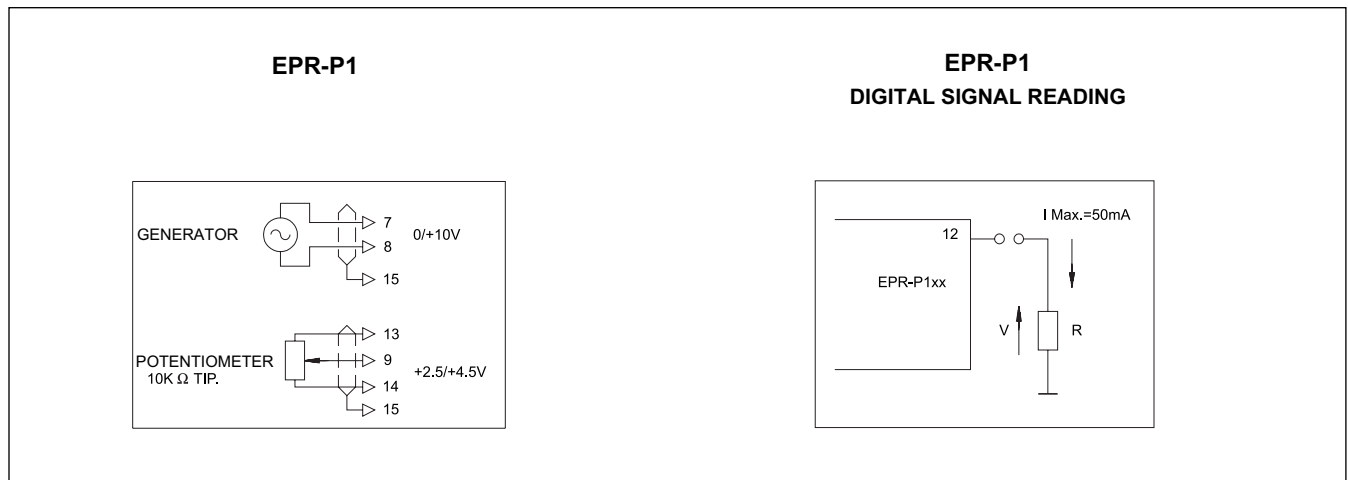

## 9 - START UP AND CONTROL SETTINGS

- 9.1.1 Insert the test point reading device and prepare a multimeter between COM-R and REF.B;
- 9.1.2 Exclude the feedback by setting the SW6 in position 2-3;
- 9.1.3 Regulate the GAIN A trimmer to the maximum (clockwise), the OFFSET A trimmer on zero (counterclockwise) and impose a reference signal of 0V;
- 9.1.4 Supply the card;
- 9.1.5 With the hydraulic system switched-off and without pressures on the transducer (transducer output signal = 4mA or 0V) rotate the trimmer offset TR till to read 0V on the multimeter;
- 9.1.6 Switch-on the hydraulic system and increase the reference signal till to reach the maximum pressure required on the system by reading it on the manometer;
- 9.1.7 Rotate the trimmer gain TR till to read -2V on the multimeter;
- 9.1.8 Restore the feedback by setting SW6 in position 1-2;
- 9.1.9 Set the reference signal to 0V and regulate the OFFSET A trimmer till to reach the minimum pressure required on the system;
- 9.1.10 Set the reference signal to 10V and regulate the GAIN A trimmer till to reach the maximum pressure required on the system;
- 9.1.11 Regulate the RAMP UP and RAMP DOWN trimmers till to reach the ramp type required;
- 9.1.12 Regulate the DAMPING trimmer to make the system response shorter. An excessive value of the damping trimmer causes vibrations on the system



## 10 - DEFAULT CONDITIONS

The electric control units are supplied factory-set.

REGULATIONS									
Card identification code	Ramp up / down	Gain	Offset	Limits mA	Switching Hz	Gain TR	Offset TR	Damping	Valve
Open loop EPR-P1XY X= 1,2,3,4	MIN	V.C.O.	MIN	V.C.O.	V.C.O.	NOT USED			*
EPR-P152	MIN	MAX	MIN	800	400	See note 1	See note 1	See note 2	RQE
EPR-P153	MIN	MAX	MIN	800	400	1	1	2	CDE
EPR-P154	MIN	MAX	MIN	800	400				MZE

V.C.O.= See code of order

\* = Pressure control and pressure reducing valves

NOTA 1: these trimmers are factory-set for a feedback signal 4 - 20mA

NOTA 2: this trimmer must be settled during the start up phase

Card identification code	SW 1	SW 2	SW 3	SW 4	SW 5	SW 6	SW 7
Open loop EPR-P1XY X= 1,2,3,4	1	irrelevant	irrelevant	irrelevant	irrelevant	2	Absent
EPR-P152	1	2	2	2	1	1	Absent
EPR-P153	1	2	2	2	1	1	Absent
EPR-P154	1	2	2	2	1	1	Absent

DESCRIPTION	
<b>SW1</b>	Ramp time: 2 long ramp, 1 short ramp
<b>SW2</b>	Transducer input: 2 current, 1 voltage
<b>SW3</b>	Transducer input: 2 current, 1 voltage
<b>SW4</b>	Output signal: 2 analogic, 1 digital
<b>SW5</b>	Loop polarity inversion: 2 direct valves, 1 piloted valves
<b>SW6</b>	Loop channel A: 2 open, 1 closed
<b>SW7</b>	Loop channel B: 2 open, 1 closed

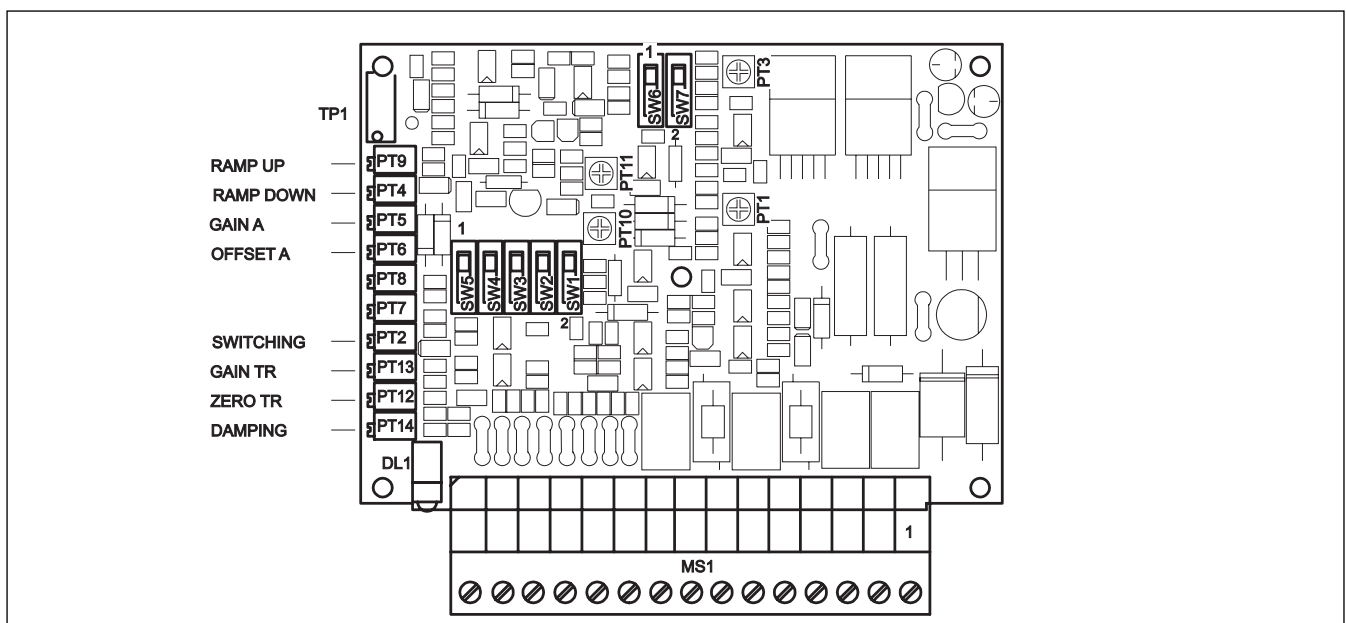



# EPR-P1\*

SERIES 11

## 11 - CARD CIRCUIT AND WIRING DIAGRAM EPR-P1

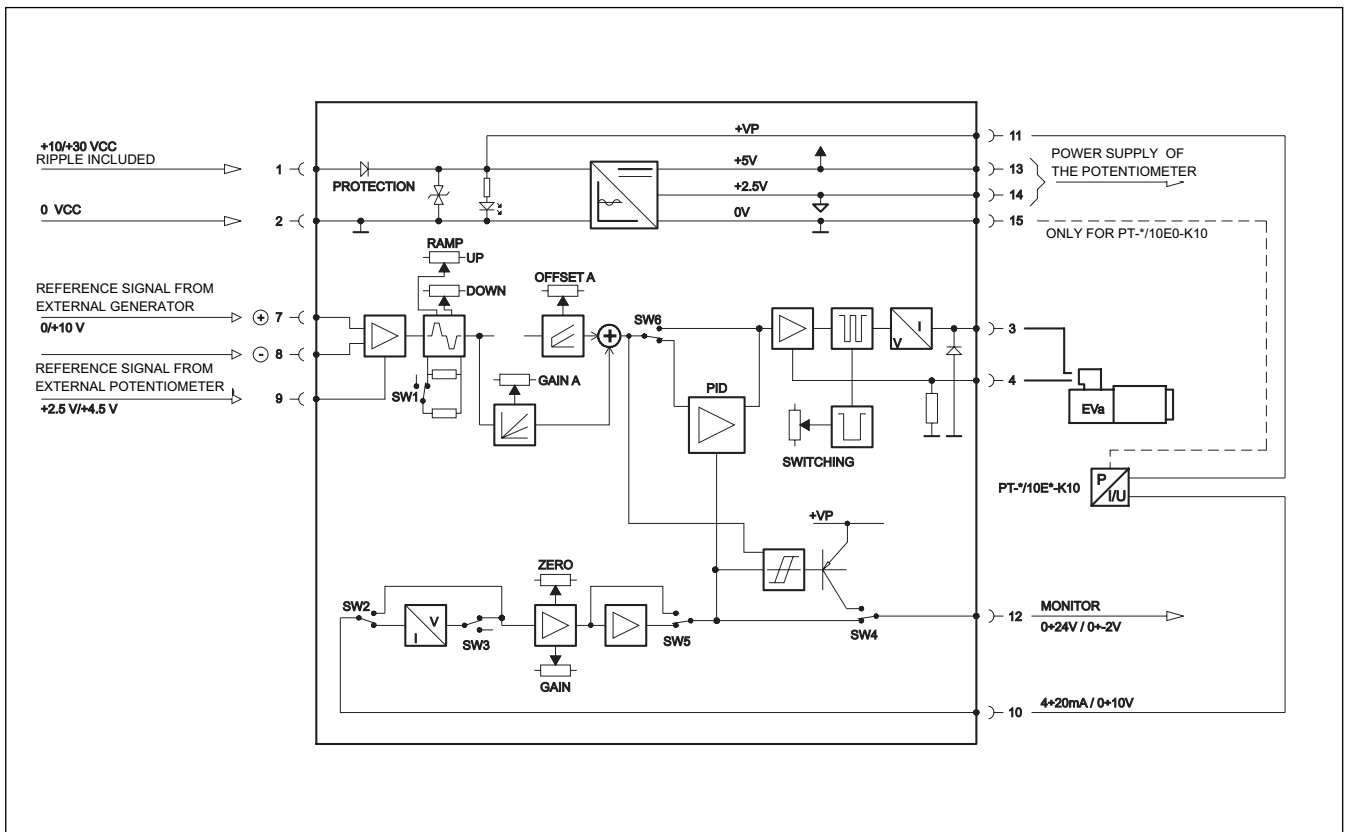



## 12 - OVERALL AND MOUNTING DIMENSIONS

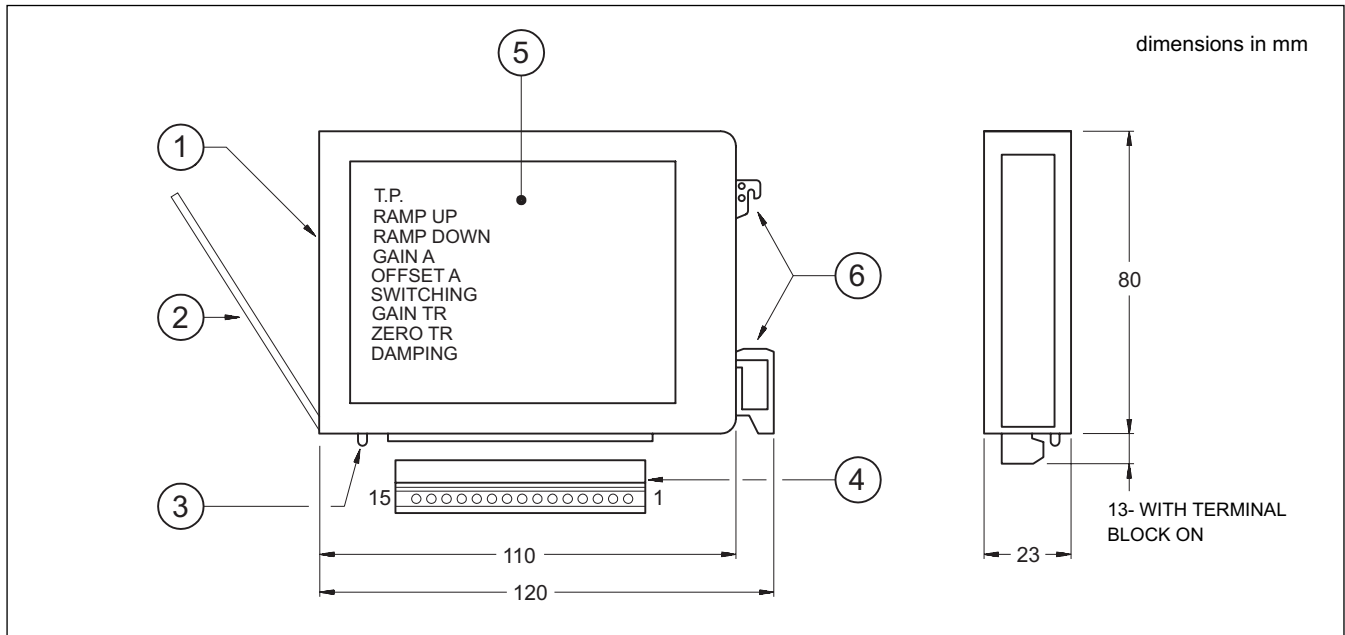

### FRONT PANNEL

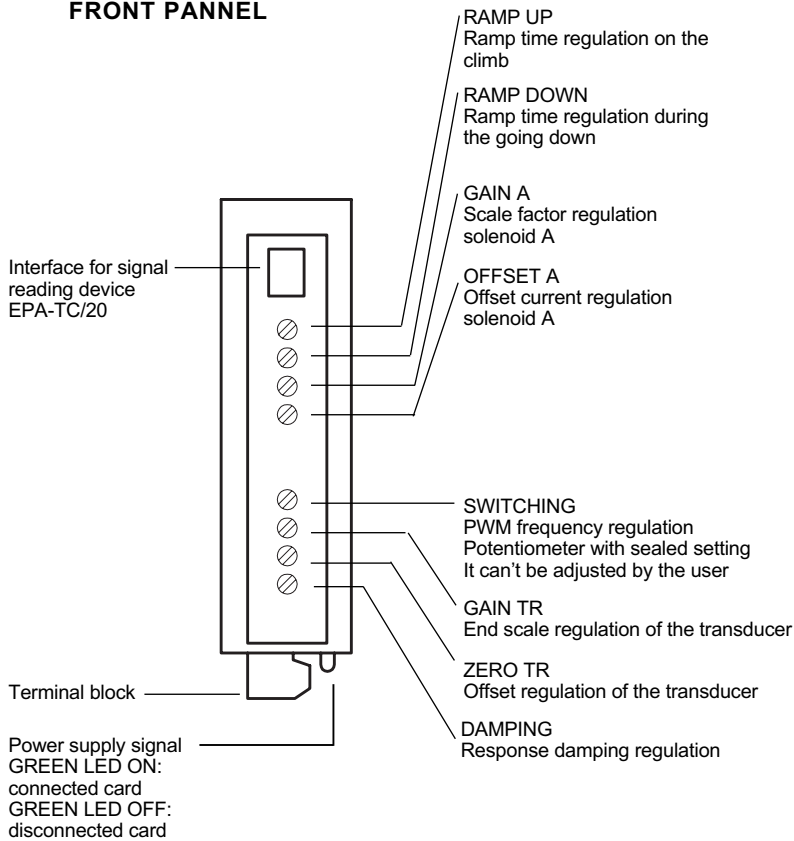

1	Regulation potentiometers and EPA-TC/20 connector interface side
2	Potentiometers protecting gate
3	Green led signalling the card power supply
4	Plugging-in 15-pole terminal strip with low cable output
5	Screen printing with card circuit and wiring diagram
6	Connection for rails type DIN EN 50022



**DIPLOMATIC OLEODINAMICA SpA**

20025 LEGNANO (MI) - P.le Bozzi, 1 / Via Edison  
Tel. 0331/472111 - Fax 0331/548328