



**DIPLOMATIC
HYDRAULICS**

81 310/107 ED



PRE*

PILOT OPERATED PRESSURE RELIEF VALVES WITH PROPORTIONAL CONTROL

SERIES 10

SUBPLATE MOUNTING

p max 350 bar

Q max (see table of performances)

OPERATING PRINCIPLE

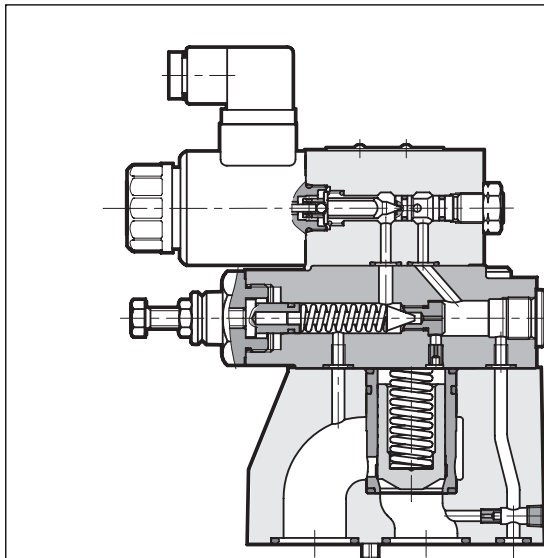

- PRE* valves are pilot operated pressure relief valves with electric proportional control and mounting interface in compliance with ISO 6264 standards (CETOP RP 121H).
- These valves are normally used to control hydraulic circuit pressure and enable the use of the full flow rate of the pump, even with settings approaching calibrated values.
- The two-stage design and wide passages ensure reduced pressure drops thereby improving the system energy performance.
- Pressure can be modulated continuously in proportion to the current supplied to the solenoid.
- These valves can be controlled directly by a current control supply unit or by means of the relevant electronic control units to exploit valve performance to the full (see par. 10).
- They are fitted with a manual pressure relief valve which is factory set to $\geq 15\%$ of the maximum value in the pressure control range.

- They are available in three sizes for flow rates up to 500 l/min and in four pressure control ranges up to 350 bar.

PERFORMANCES (obtained with mineral oil with viscosity of 36 cSt at 50°C and electronic control cards)		PRE10	PRE25	PRE32
Maximum operating pressure:	bar	350		
Minimum controlled pressure		see Δp -Q diagram		
Maximum flow	l/min	200	400	500
Step response		see paragraph 5		
Hysteresis	% of p nom	< 5%		
Repeatability	% of p nom	< $\pm 1,5\%$		
Electrical characteristic		see paragraph 7		
Ambient temperature range	°C	-10 / +50		
Fluid temperature range	°C	-20 / +80		
Fluid viscosity range	cSt	10 ÷ 400		
Fluid contamination degree		According to ISO 4406:1999 class 18/16/13		
Recommended viscosity	cSt	25		
Mass:	kg	5	5,8	8

HYDRAULIC SYMBOL

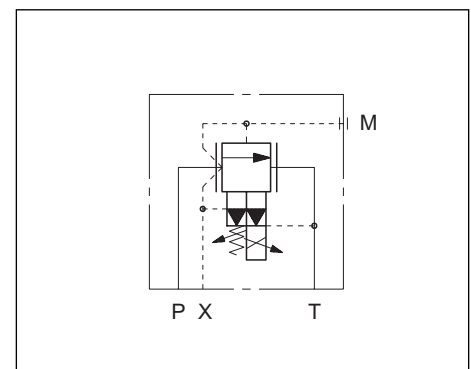



1 - IDENTIFICATION CODE

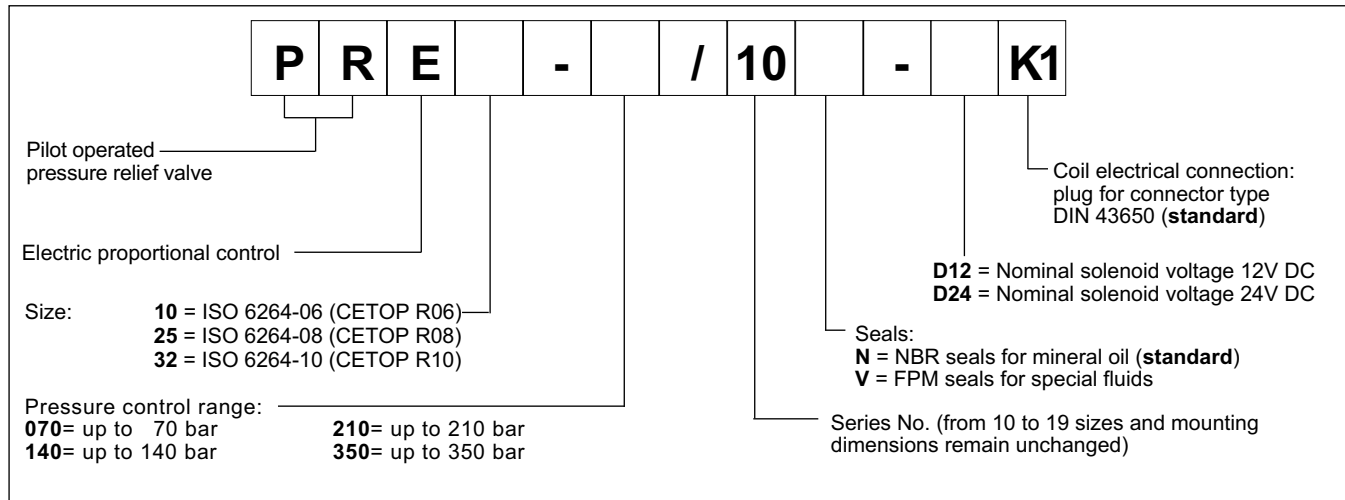

2 - CHARACTERISTIC CURVES (measured with viscosity of 36 cSt at 50°C)

PRESSURE CONTROL $p=f(I)$

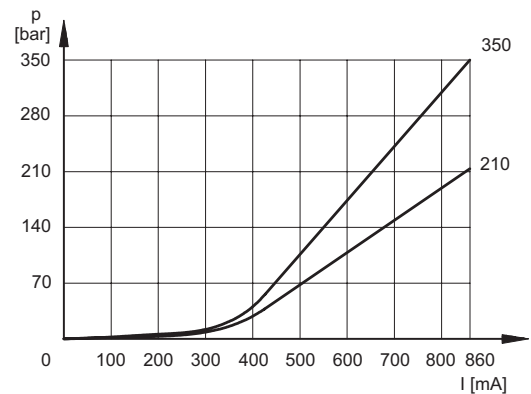
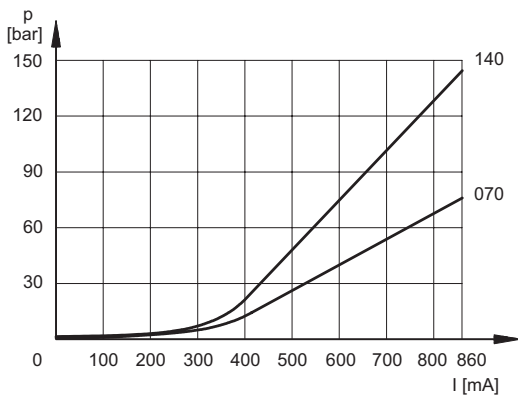

PRESSURE CONTROL $p=f(Q)$

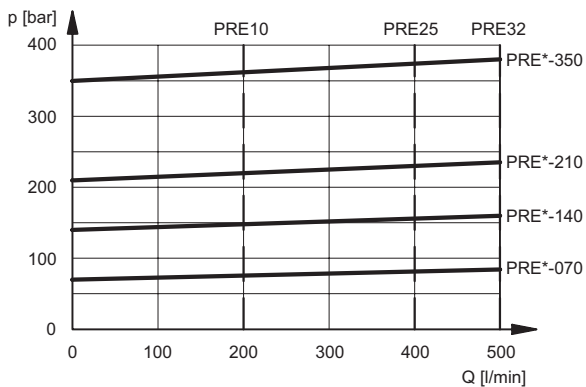

PRESSURE DROP $\Delta p = f(Q)$

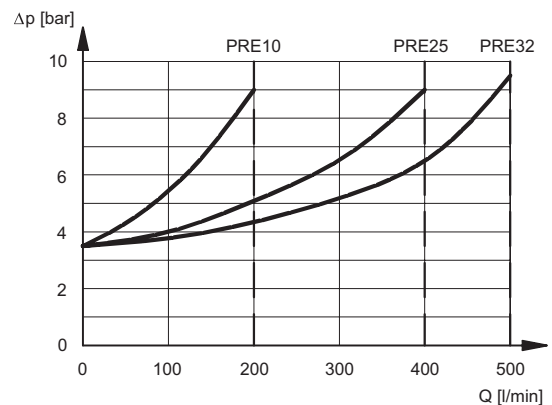



3 - HYDRAULIC FLUIDS

Use mineral oil-based hydraulic fluids HL or HM type, according to ISO 6743-4. For these fluids, use NBR seals (code N). For fluids HFDR type (phosphate esters) use FPM seals (code V). For the use of other kinds of fluid such as HFA, HFB, HFC, please consult our technical department. Using fluids at temperatures higher than 80 °C causes a faster degradation of the fluid and of the seals characteristics.

The fluid must be preserved in its physical and chemical characteristics.

4 - ELECTRICAL CHARACTERISTICS

Proportional solenoid

The proportional solenoid comprises two parts: tube and coil.

The tube, screwed to the valve body, contains the armature which is designed to maintain friction to a minimum thereby reducing hysteresis.

The coil is mounted on the tube secured by means of a lock nut and can be rotated through 360° depending on installation clearances.

NOMINAL VOLTAGE	V DC	12	24
RESISTANCE (at 20°C)	Ω	3.66	17.6
MAXIMUM CURRENT	A	1.88	0.86
DUTY CYCLE		100%	
ELECTROMAGNETIC COMPATIBILITY (EMC)		According to 89/336 CEE	
emissions	EN 50081-1		
immunity	EN 50082-2		
CLASS OF PROTECTION:		IP 65	
Atmospheric agents (CEI EN 60529)			

5 - STEP RESPONSE (obtained with mineral oil with viscosity of 36 cSt at 50°C and electronic control cards)

Step response is the time taken for the valve to reach 90% of the set pressure value following a step change of reference signal.

The table illustrates typical step response times measured with input flow rate of Q = 50 l/min.

REFERENCE SIGNAL STEP	0 → 100%	100 → 0%
Step response [ms]	120	90

6 - INSTALLATION

We recommend to install the PRE* valve either in horizontal position, or vertical position with the solenoid downward. If the valve is installed in vertical position and with the solenoid upward, you must consider possible variations of the minimum controlled pressure, if compared to what is indicated in paragraph 2.

Ensure that there is no air in the hydraulic circuit. In particular applications, it can be necessary to vent the air entrapped in the solenoid tube, by using the apposite drain screw in the solenoid tube (see par. 4 - 5 - 6). At the end of the operation, make sure of having correctly screwed the drain screw.

Connect the T port on the valve directly to the tank. Add any backpressure value detected in the T line to the controlled pressure value. Maximum admissible backpressure in the T line, under operational conditions, is 2 bar.

Valves are fixed by means of screws or tie rods on a flat surface with planarity and roughness equal to or better than those indicated in the relative symbols. If minimum values are not observed, fluid can easily leak between the valve and support surface.

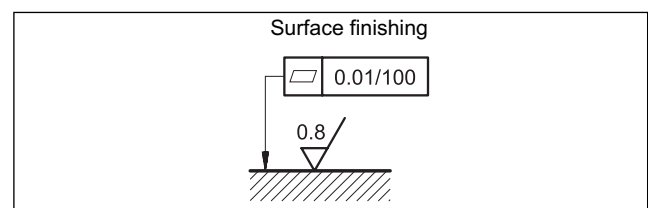



8 - PRE25 OVERALL AND MOUNTING DIMENSIONS

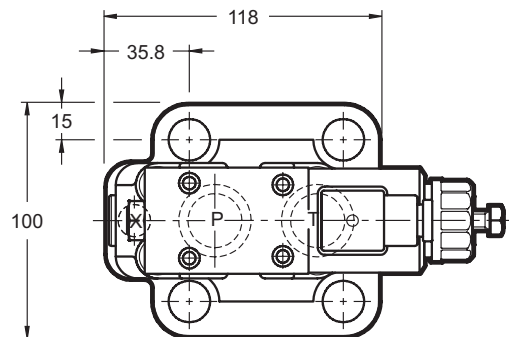
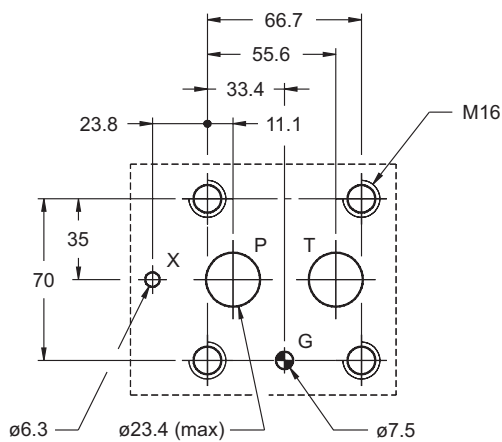
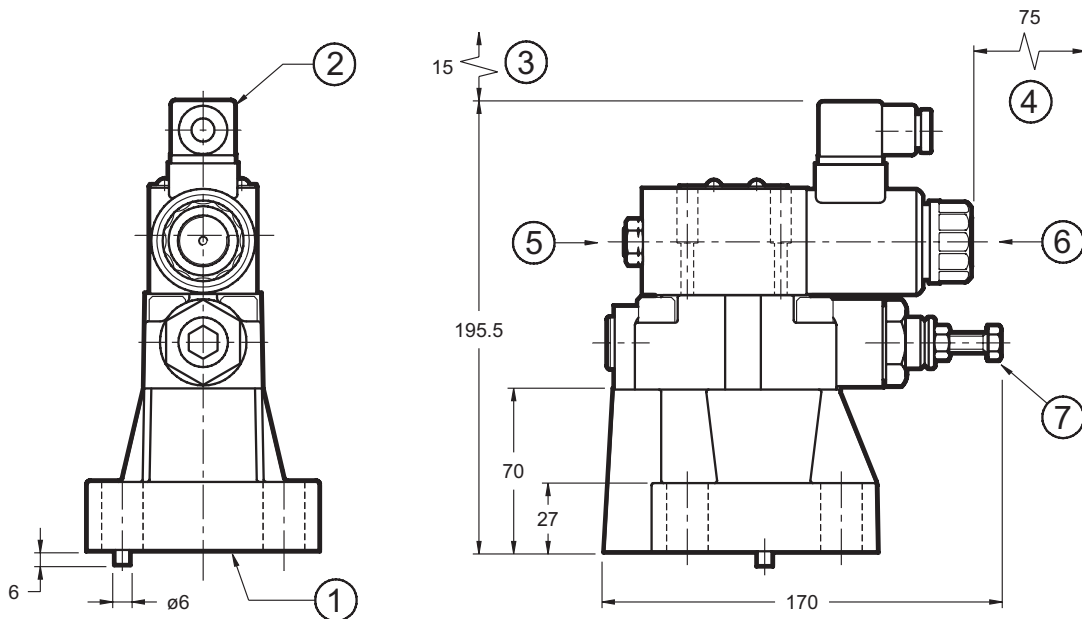

Mounting interface: ISO 6264-08-13-1-97
(CETOP 4.4.2-2-R08-350)

dimensions in mm

Fastening bolts: 4 bolts M16x50
Torque: 170 Nm

NOTE: at the first start up, or after a long period of no use, it is necessary to vent the air through the breather (6) placed at the end of the solenoid tube.

1	Mounting surface with sealing rings: 2 OR type 3118 - 90 shore (29.82 x 2.62) 1 OR type 109 - 90 shore (9.13 x 2.62)
2	DIN 43650 electric connector
3	Connector removal space
4	Coil removal space
5	Factory setting sealing (we recommend not unscrewing the nut)
6	Breather (male hexagonal spanner 4)
7	Pressure relief valve (factory set)



9 - PRE32 OVERALL AND MOUNTING DIMENSIONS

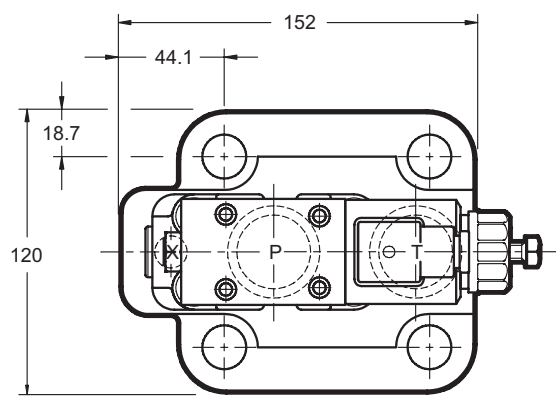
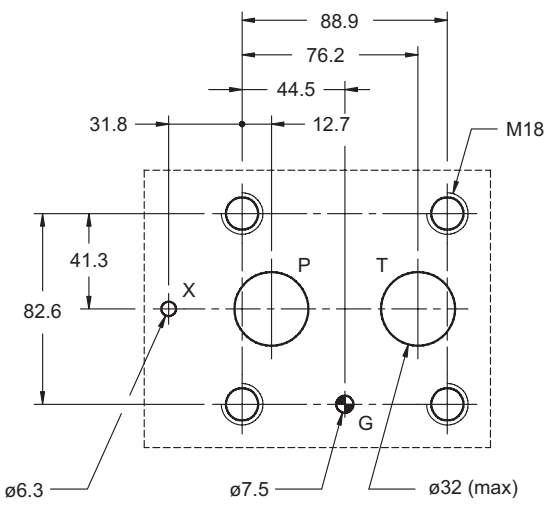
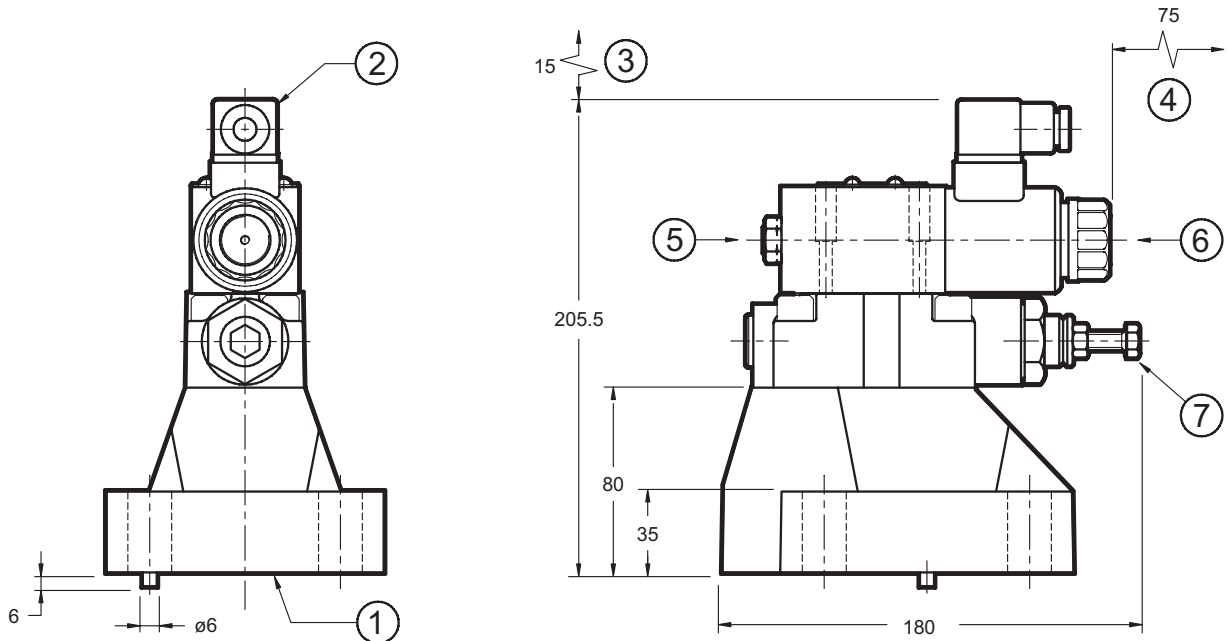

dimensions in mm

Mounting interface: ISO 6264-10-17-1-97
(CETOP 4.4.2-2-R10-350)

Fastening bolts: N. 4 bolts M18x60
Torque: 235 Nm

NOTE: at the first start up, or after a long period of no use, it is necessary to vent the air through the breather (6) placed at the end of the solenoid tube.

1	Mounting surface with sealing rings: 2 OR type 4137 - 90 shore (34.52 x 3.53) 1 OR type 109 - 90 shore (9.13 x 2.62)
2	DIN 43650 electric connector
3	Connector removal space
4	Coil removal space
5	Factory setting sealing (we recommend not unscrewing the nut)
6	Breather (male hexagonal spanner 4)
7	Pressure relief valve (factory set)



10 - ELECTRONIC CONTROL UNITS

EDC-112	for solenoid 24V DC	plug version	see cat.89 120
EDM-M112	for solenoid 24V DC	DIN EN 50022 rail mounting	see cat. 89 250
EDM-M142	for solenoid 12V DC		
UEIK-11	for solenoid 24V DC	Eurocard type	see cat. 89 300

11 - SUBPLATES (see cat. 51 000)

	PRE10	PRE25	PRE32
Type	PMRQ3-AI4G rear ports	PMRQ5-AI5G rear ports	PMRQ7-AI7G rear ports
PT port dimesions	1/2" BSP	1" BSP	1" ¼ BSP
X port dimensions	1/4" BSP	1/4" BSP	1/4" BSP



PRE*
SERIES 10



DIPLOMATIC OLEODINAMICA SpA
20025 LEGNANO (MI) - P.le Bozzi, 1 / Via Edison
Tel. 0331/472111 - Fax 0331/548328