

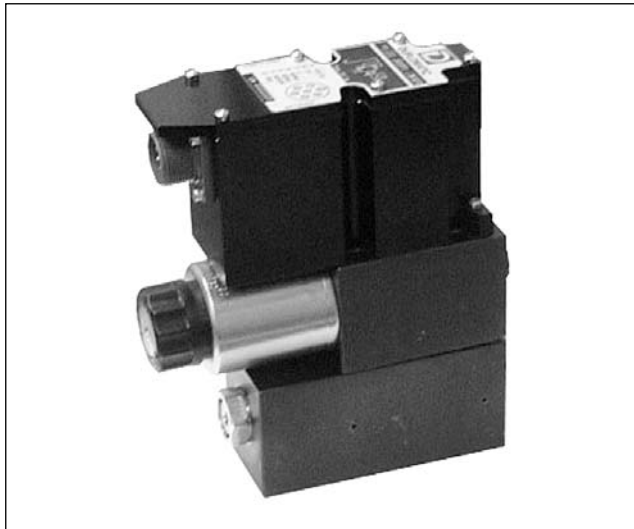

**DIPLOMATIC**  
HYDRAULICS

81 250/107 ED



# PRE3G

## PILOT OPERATED PRESSURE CONTROL VALVE WITH PROPORTIONAL CONTROL AND INTEGRATED ELECTRONICS

SERIES 11

**SUBPLATE MOUNTING**  
**ISO 4401-03 (CETOP 03)**

**p max 350 bar**  
**Q max 50 l/min**

### MOUNTING SURFACE

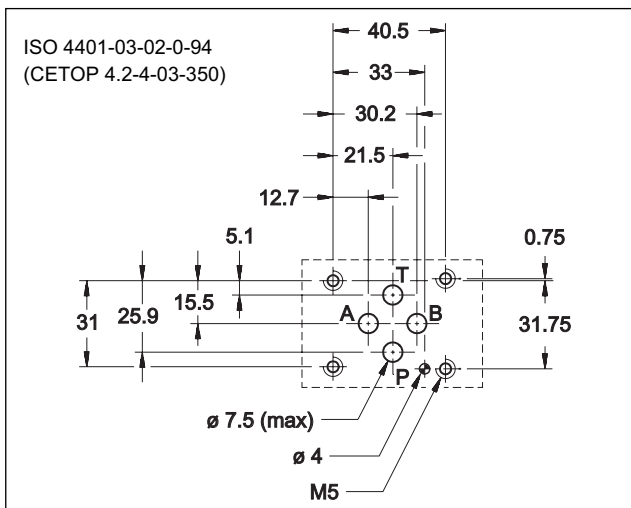

### OPERATING PRINCIPLE

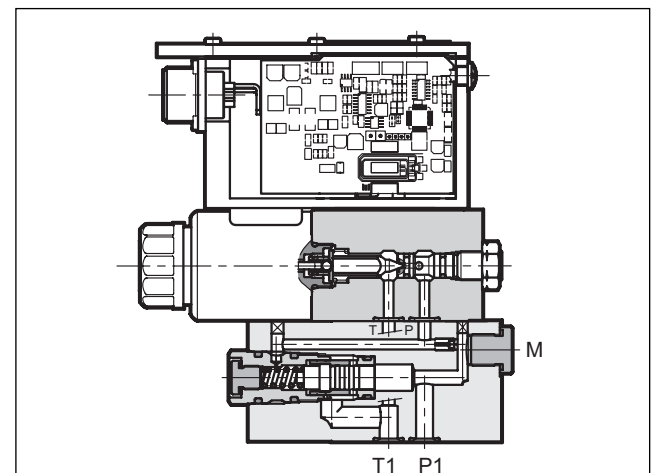

— The PRE3G valve is a pilot operated pressure control valve with integrated electric proportional control and mounting interface in compliance with ISO 4401 (CETOP RP 121H) standards.

- It is suitable to modulate the pressure in hydraulic circuits.
- Pressure can be modulated continuously in proportion to the reference signal.
- The valve is controlled directly by an integrated digital amplifier (see par. 4).
- The valve is available in four pressure control ranges up to 350 bar.

### PERFORMANCES

(obtained with mineral oil with viscosity of 36 cSt at 50°C and digital integrated electronics)

Maximum operating pressure: - P port - T port	bar	350 2
Minimum controlled pressure	see $p_{min} = f(Q)$ diagram	
Minimum flow	l/min	2
Nominal flow		30
Maximum flow (see $p_{min} = f(Q)$ diagram)		50
Step response	see paragraph 3	
Hysteresis	% of p nom	< 3%
Repeatability	% of p nom	< $\pm 1\%$
Electrical characteristic	see paragraph 4.3	
Ambient temperature range	°C	-10 / +50
Fluid temperature range	°C	-20 / +80
Fluid viscosity range	cSt	10 + 400
Fluid contamination degree	According to ISO 4406:1999 class 18/16/13	
Recommended viscosity	cSt	25
Mass:	kg	3,6

### HYDRAULIC SYMBOL

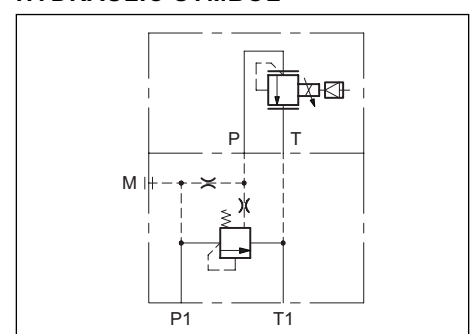



## 1 - IDENTIFICATION CODE

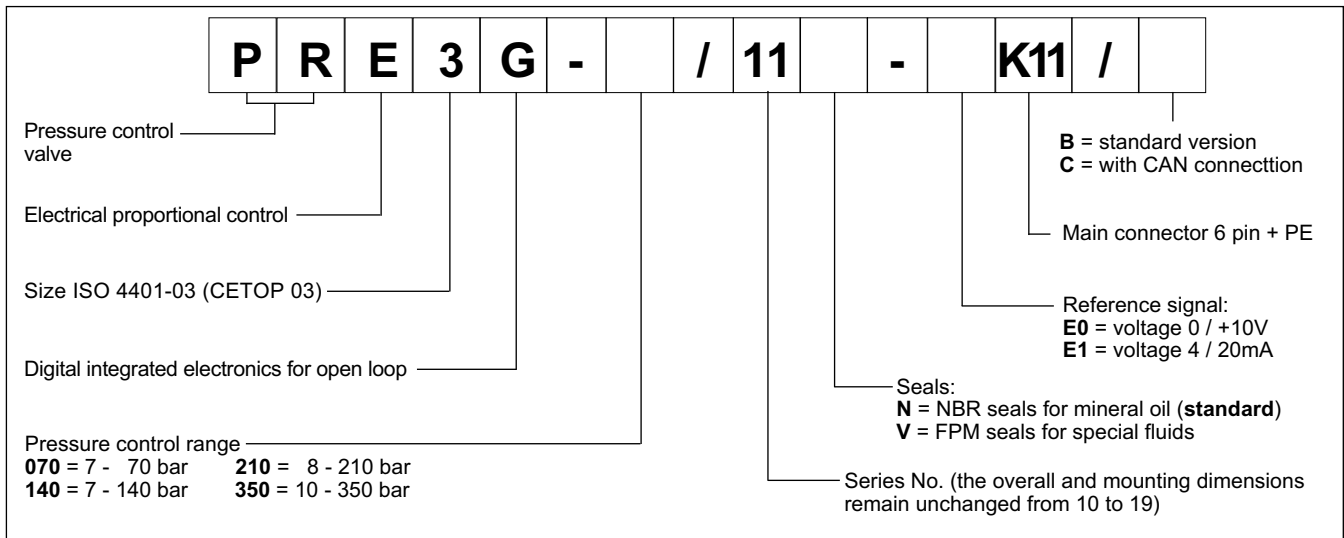

## 2 - CHARACTERISTIC CURVES (measured with viscosity of 36 cSt at 50°C)

Typical control curves according to the current supplied to the solenoid (D24 version with maximum current 860 mA) for pressure control ranges: 070, 140, 210, 350, measured with input flow rate  $Q=10$  l/min.

The curves are obtained without any hysteresis and linearity compensation and they are measured without any backpressure in T. The full scale pressure is set in factory with a flow rate of 10 l/min. In case of higher flow rate, the full scale pressure will increase considerably (see diagram  $p_{max} = f(Q)$ )

**PRESSURE CONTROL  $p=f(I)$**

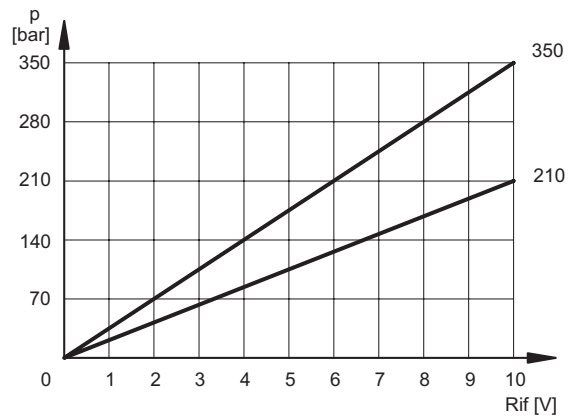
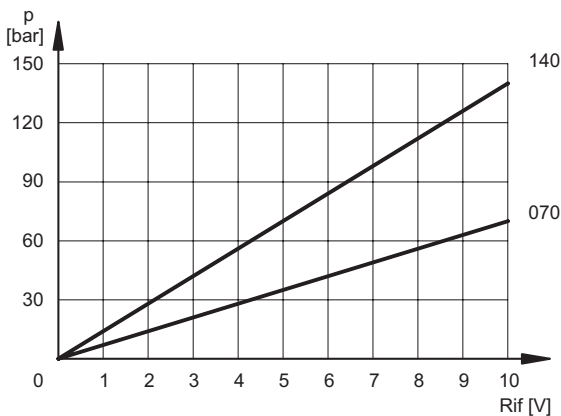

**MINIMUM CONTROLLED PRESSURE  $p_{min} = f(Q)$**

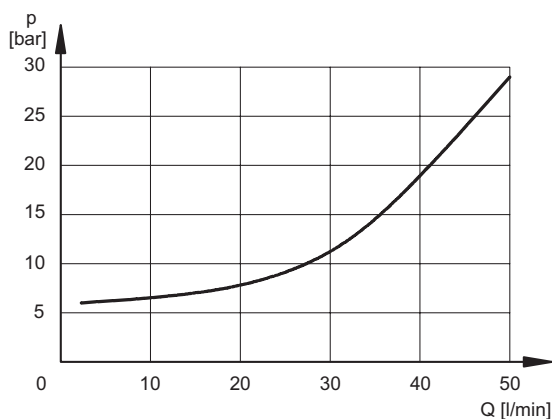

**PRESSURE VARIATION  $p_{max} = f(Q)$**

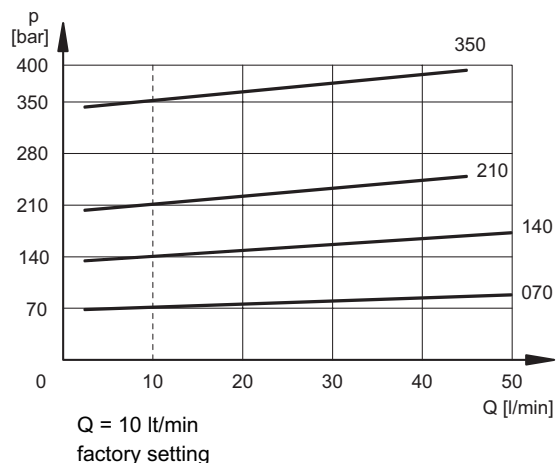



### 3 - RESPONSE TIMES (obtained with mineral oil with viscosity of 36 cSt at 50°C and with digital integrated electronics)

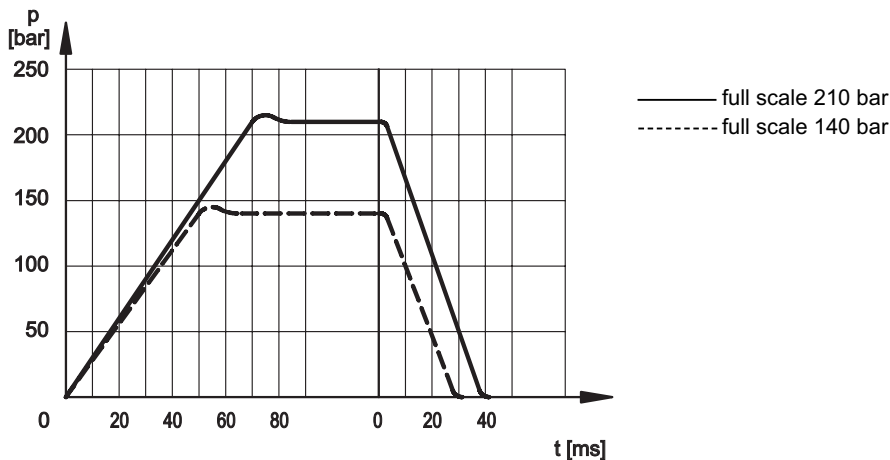

**NOTE:** Response times are obtained by using valves with a full scale of 140 and 210 bar, with an input flow rate of 10 l/min and a pressure oil volume of 0,5 lt. The response time is affected both by the flow rate and the oil volume in the pipework.

## 4 - ELECTRICAL CHARACTERISTICS

### 4.1 - Digital integrated electronics

The proportional valve is controlled by a digital amplifier (driver), which incorporates a microprocessor that controls, via software, all the valve functions, such as:

- continuous converting (0,5ms) of the voltage reference signal (E0) or of the current reference signal (E1) in a digital value
- generation of up and down ramps (see **NOTE**)
- gains limit (see **NOTE**)
- compensation of the dead band
- linearization of the characteristic curve
- regulation of the current to the solenoid
- dynamic regulation of PWM frequency
- protection of the solenoid outputs against possible short circuits

**NOTE:** these parameters can be set through the connection to the CAN connector, by means of a personal computer and relevant software (see paragraph 5.3)

The digital driver enables the valve to reach better performance compared to the analogic version, such as:

- reduced hysteresis and improved repeatability
- reduced response times
- linearization of the characteristic curve which is optimised in factory for each valve
- complete interchangeability in case of valve replacement
- possibility to set, via software, the functional parameters
- possibility to interface a CAN-Open network
- possibility to perform a diagnostic program by means of the CAN connection
- high immunity to electromagnetic troubles

## 4.2 - Functional block diagram

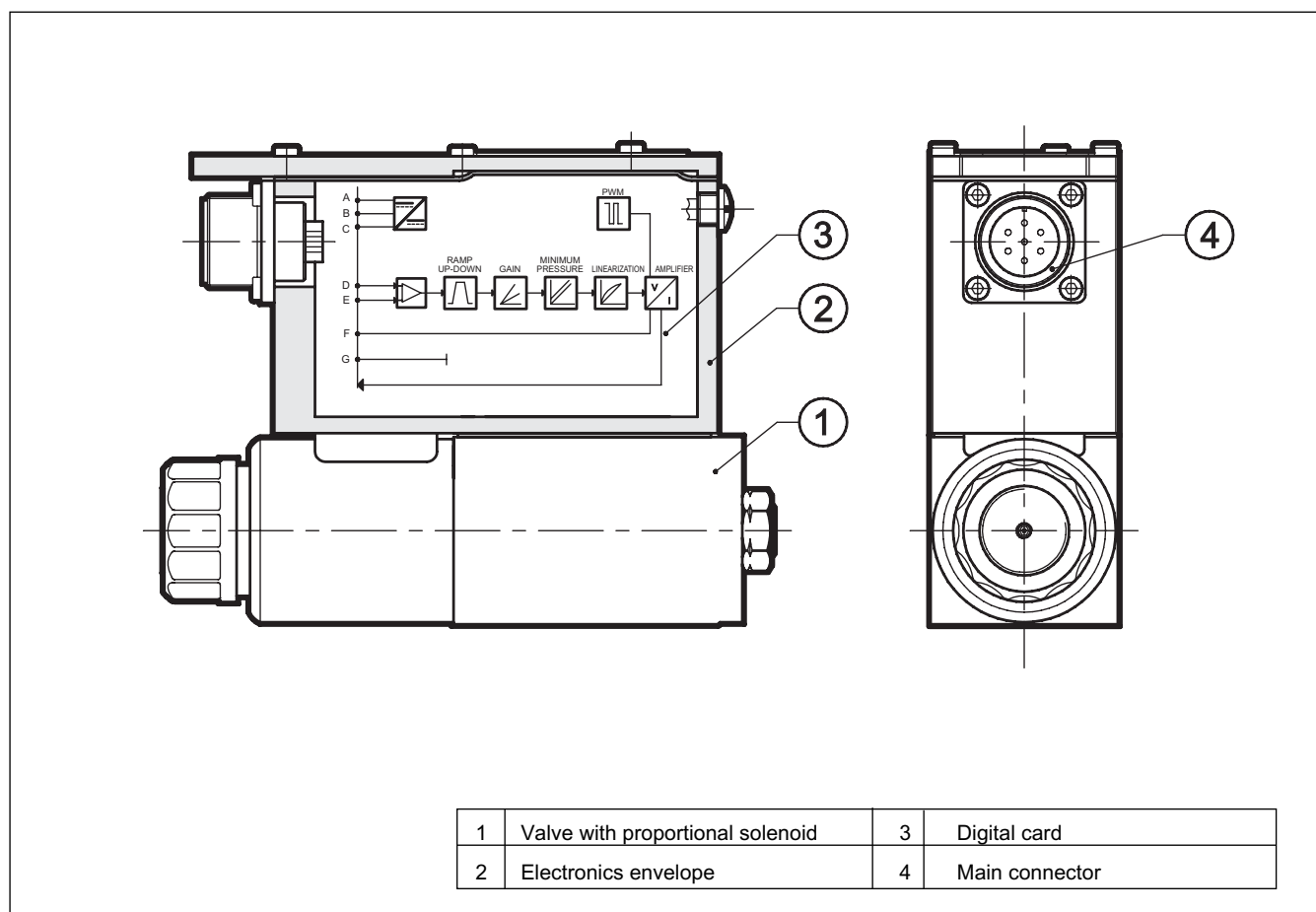

## 4.3 - Electrical characteristics

<b>NOMINAL VOLTAGE</b>	V DC	24 V DC (from 19 to 35 V DC, ripple max 3 Vpp)
<b>ABSORBED POWER</b>	W	50
<b>MAXIMUM CURRENT</b>	A	1,88
<b>DUTY CICLE</b>		100%
<b>VOLTAGE SIGNAL (E0)</b>	V DC	0 ± 10 (Impedence Ri > 50 KΩ)
<b>CURRENT SIGNAL (E1)</b>	mA	4 ± 20 (Impedence Ri = 500 Ω)
<b>ALARMS</b>		Overload and electronics overheating
<b>COMMUNICATION</b>		Interface of the optoisolated industrial Field-bus type CAN-Bus ISO 11898
<b>MAIN CONNECTOR</b>		7 - pin MIL-C-5015-G (DIN 43563)
<b>CAN-BUS CONNECTOR</b>		M12-IEC 60947-5-2
<b>ELECTROMAGNETIC COMPATIBILITY (EMC)</b>		
<b>EMISSIONS</b> EN 50081-1		according to 89/336 CEE standards
<b>IMMUNITY</b> EN 50082-2		
<b>PROTECTION AGAINST ATMOSPHERIC AGENTS</b>		IP67 (CEI EN 60529 standards)



## 5 - OPERATING MODALITIES

The digital driver of PRE3G valve may be used with different functions and operating modalities, depending on the requested performances.

### 5.1 - Standard version with voltage reference signal (E0)

This is the most common version; it makes the valve completely interchangeable with the traditional proportional valves with analog type integrated electronics. The valve has only to be connected as indicated below.

This version doesn't allow the setting of the valve parameters, for example the ramps must be performed in the PLC program, as well as the reference signal limit.

Standard connection scheme with voltage reference signal (E0)

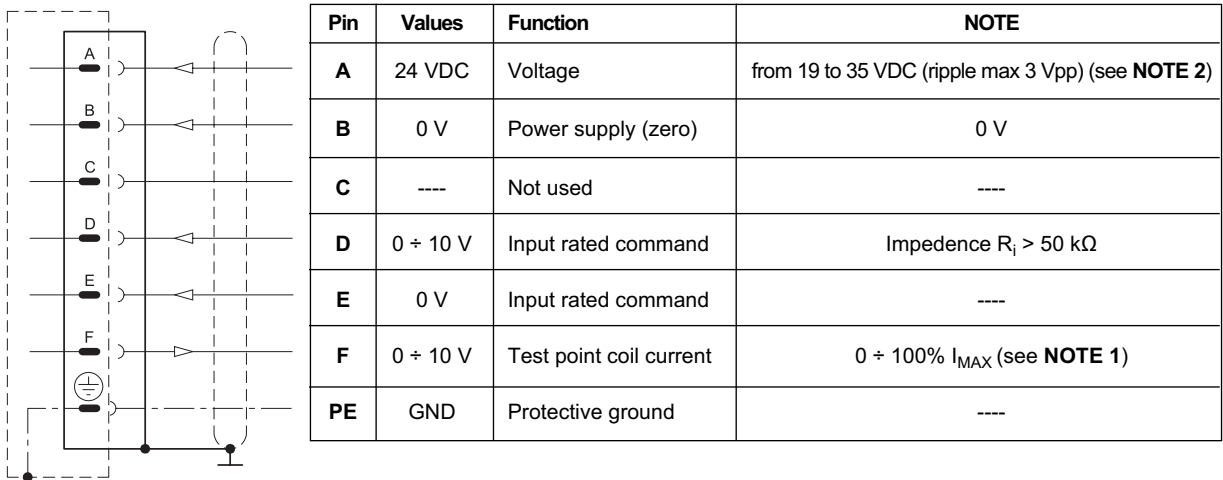

**NOTE:** if only one input signal (single-end) is available, the Pin B (0V power supply) and the Pin E (0V reference signal) must be connected through a jumper and both connected to GND, electric panel side.

### 5.2 - Standard version with current reference signal (E1)

This version has characteristics which are similar to the previous one, with the difference that in this case the reference signal is supplied in current 4 - 20 mA. With the 4 mA signal the valve is at zero value, while with 20 mA signal the valve is at the maximum setting value.

Standard connection scheme with current reference signal (E1)

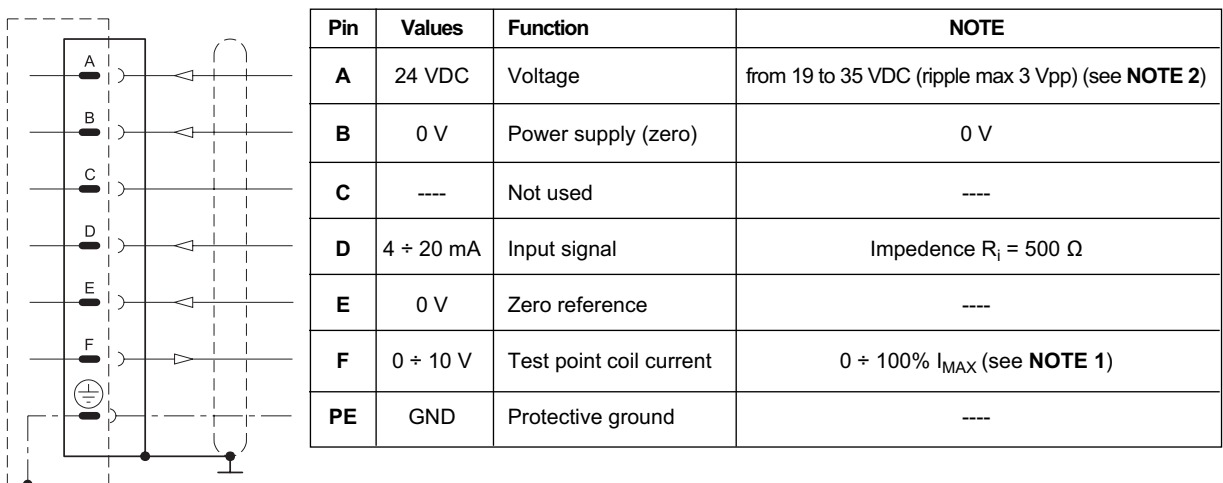

**NOTE for the wiring:** connections must be made via the 7-pin plug mounted on the amplifier. Recommended cable sizes are 0,75 mm<sup>2</sup> for cables up to 20m and 1,00 mm<sup>2</sup> for cables up to 40m, for power supply. The signal cables must be 0,50 mm<sup>2</sup>. A suitable cable would have 7 cores, a separate screen for the signal wires and an overall screen.

**NOTE 1:** read the test point Pin F in relation to Pin B (0V)

**NOTE 2:** forecast on Pin A (24 VDC) an external fuse for electronic protection. Fuse characteristics: 5A/50V quick type.



### 5.3 - Version with parameters set by means of CAN connector (version C)

This version enables the setting of some parameters of the valve, by connecting the CAN connector to a traditional computer.

To do this, the following devices are to be ordered separately:

- interface device for USB port **CANPC-USB/10** - cod. 3898101001, with the relevant configuration software, with a communication cable (L = 3 meters) and a hardware converter for connecting the valve at PC USB port.

The parameters that can be set are described below:

#### Nominal pressure

The "nominal pressure" parameter limits the maximum current to the solenoid, therefore it sets the desired nominal pressure corresponding to the positive value of the input reference (10 V or 20 mA).

Default value = 100% of full scale

Range: from 100% to 50% of full scale

#### PWM Frequency

Sets the PWM frequency, which is the pulsating frequency of the control current. The PWM decrease improves the valve accuracy, decreasing the regulation stability.

The PWM increase improves the regulation stability, causing a higher hysteresis.

Default value = 300 Hz

Range 50 ÷ 500 Hz

#### Ramps

Increase time of Ramp R1: sets the current increase time for a variation from 0 to 100% of the input reference.

Decrease time of Ramp R2: sets the current decrease time for a variation from 0 to 100% of the input reference.

Min time = 0,001 sec.

Max time = 40,000 sec.

Default time = 0,001 sec.

#### Diagnostics

Provides several information parameters, such as:

- The electronic driver status (Working or Broken)
- The active regulation
- Input reference
- Current value

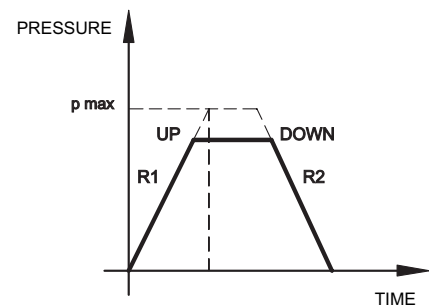
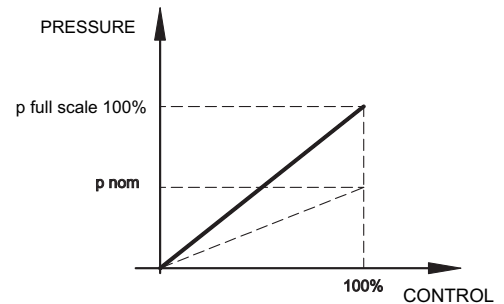



## 5.4 - Version with CAN-Bus interface (version C)

This version allows the valve piloting through the industrial field bus CAN-Open, according to ISO 11898 standards.

The CAN connector must be connected (see scheme) as a slave node of the CAN-Open bus, while the main connector is wired only for the power supply (pin A and B + earth)

The most important characteristics of a CAN - Open connection are:

- Parameter storage also in PLC
- Parameters setting in real-time (PDO communication)
- On-line valve diagnostics
- Easy wiring with the serial connection
- Communication program according to international standards

For detailed information on the CAN-Open communication software, see cat. 89 800.

### CAN connector connection scheme

Pin	Values	Function
1	CAN_SHLD	monitor
2	CAN +24VDC	BUS + 24 VDC (max 30 mA)
3	CAN 0 DC	BUS 0 VDC
4	CAN_H	BUS line (high signal)
5	CAN_L	BUS line (low signal)

**N.B.** : insert a 120 Ω resistance on pin 4 and pin 5 of the CAN connector when the valve is the closure knot of the CAN network.

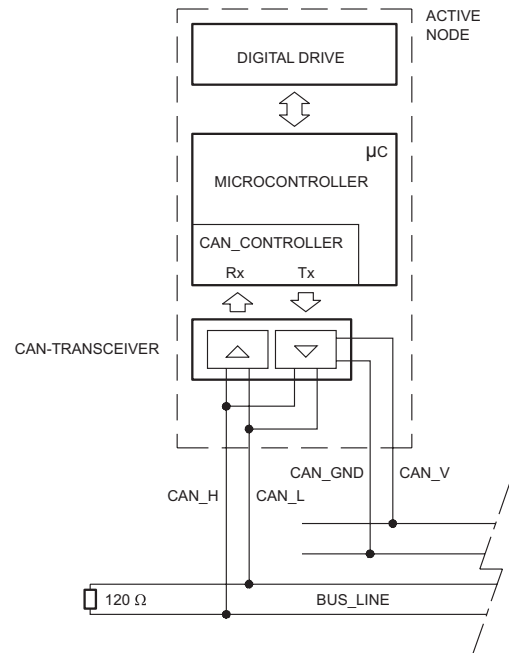

## 6 - INSTALLATION

We recommend to install the PRE3G valve either in horizontal position, or vertical position with the solenoid downward. If the valve is installed in vertical position and with the solenoid upward, you must consider possible variations of the minimum controlled pressure, if compared to what is indicated in paragraph 2.

Ensure that there is no air in the hydraulic circuit. In particular applications, it can be necessary to vent the air entrapped in the solenoid tube, by using the appropriate drain screw in the solenoid tube. Ensure that the solenoid tube is always filled with oil (see paragraph 8). At the end of the operation, make sure of having correctly replaced the drain screw.

Connect the valve T port directly to the tank. Add any backpressure value detected in the T line to the controlled pressure value. Maximum admissible backpressure in the T line, under operational conditions, is 2 bar.

Valves are fixed by means of screws or tie rods on a flat surface with planarity and roughness equal to or better than those indicated in the relative symbols. If minimum values are not observed, fluid can easily leak between the valve and support surface.

## 7 - HYDRAULIC FLUIDS

Use mineral oil-based hydraulic fluids HL or HM type, according to ISO 6743-4. For these fluids, use NBR seals (code N). For fluids HFDR type (phosphate esters) use FPM seals (code V). For the use of other fluid types such as HFA, HFB, HFC, please consult our technical department.

Using fluids at temperatures higher than 80 °C causes a faster degradation of the fluid and of the seals characteristics. The fluid must be preserved in its physical and chemical characteristics.

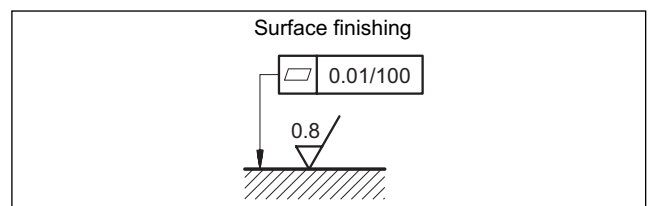



## 8 - OVERALL AND MOUNTING DIMENSIONS

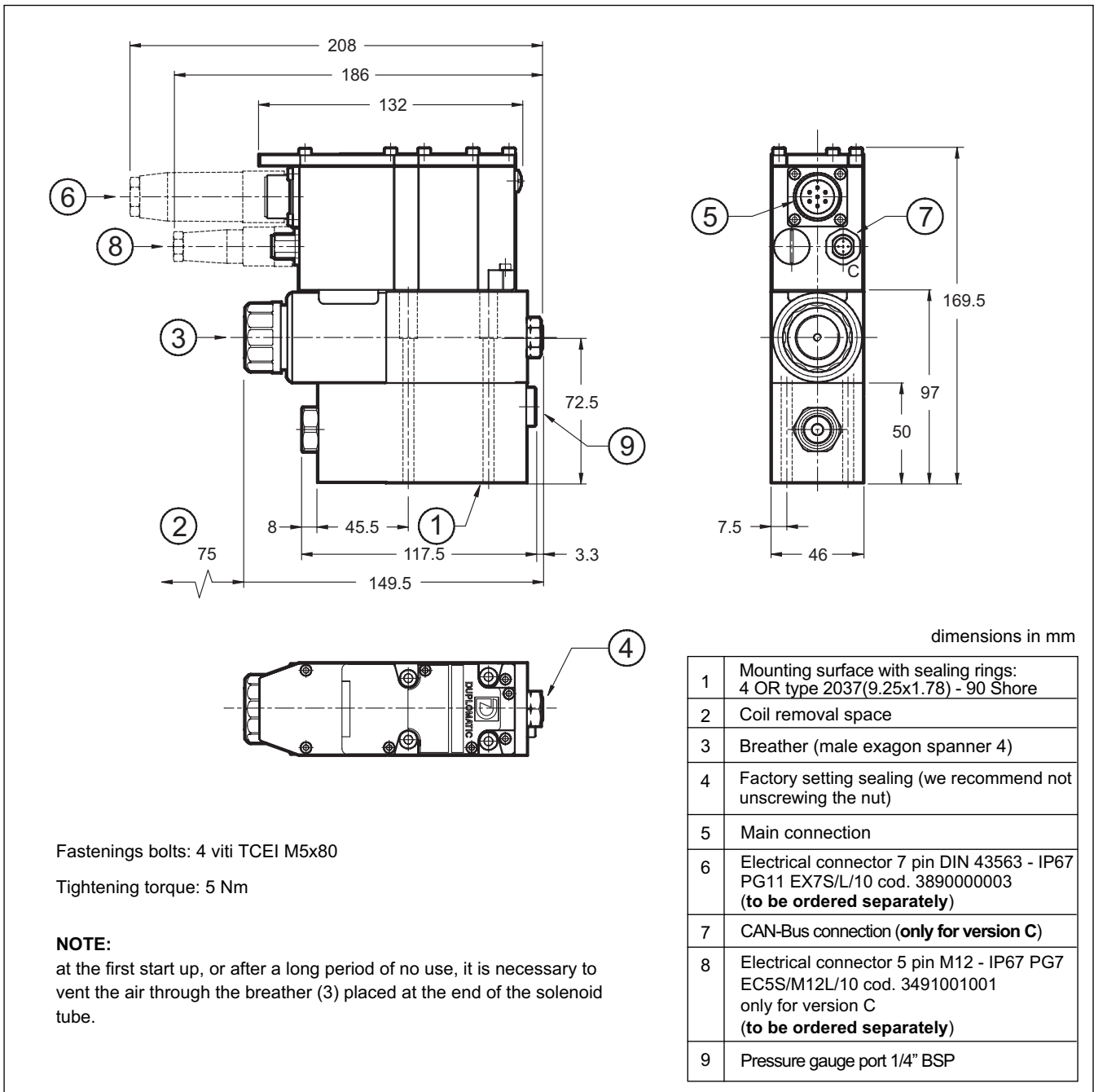

Fastenings bolts: 4 viti TCEI M5x80

Tightening torque: 5 Nm

**NOTE:**

at the first start up, or after a long period of no use, it is necessary to vent the air through the breather (3) placed at the end of the solenoid tube.

## 9 - SUBPLATE (see catalogue 51 000)

PMMD-AI3G with ports on rear
PMMD-AL3G with side ports
Ports dimensions P, T, A, B: 3/8" BSP thread

<p><b>DIPLOMATIC HYDRAULICS</b></p>	<p><b>DIPLOMATIC OLEODINAMICA SpA</b> 20025 LEGNANO (MI) - P.le Bozzi, 1 / Via Edison Tel. 0331/47211 - Fax 0331/548328</p>	
---	---	--