

RM4*-MP

SUBPLATE WITH PRESSURE RELIEF VALVE

SERIES 30

- The RM4*-MP subplate includes a pressure relief valve with P and T threaded ports.
- It is used as mounting surface for P2D and P4D subplates on power packs.
- It is available in four pressure adjustment ranges up to 350 bar.
- It is normally supplied with a countersunk hex adjustment screw, locking nut and maximum adjustment limiting device.

THREADED PORTS

p max 350 bar
Q max 100 l/min

1 - OVERALL AND MOUNTING DIMENSIONS

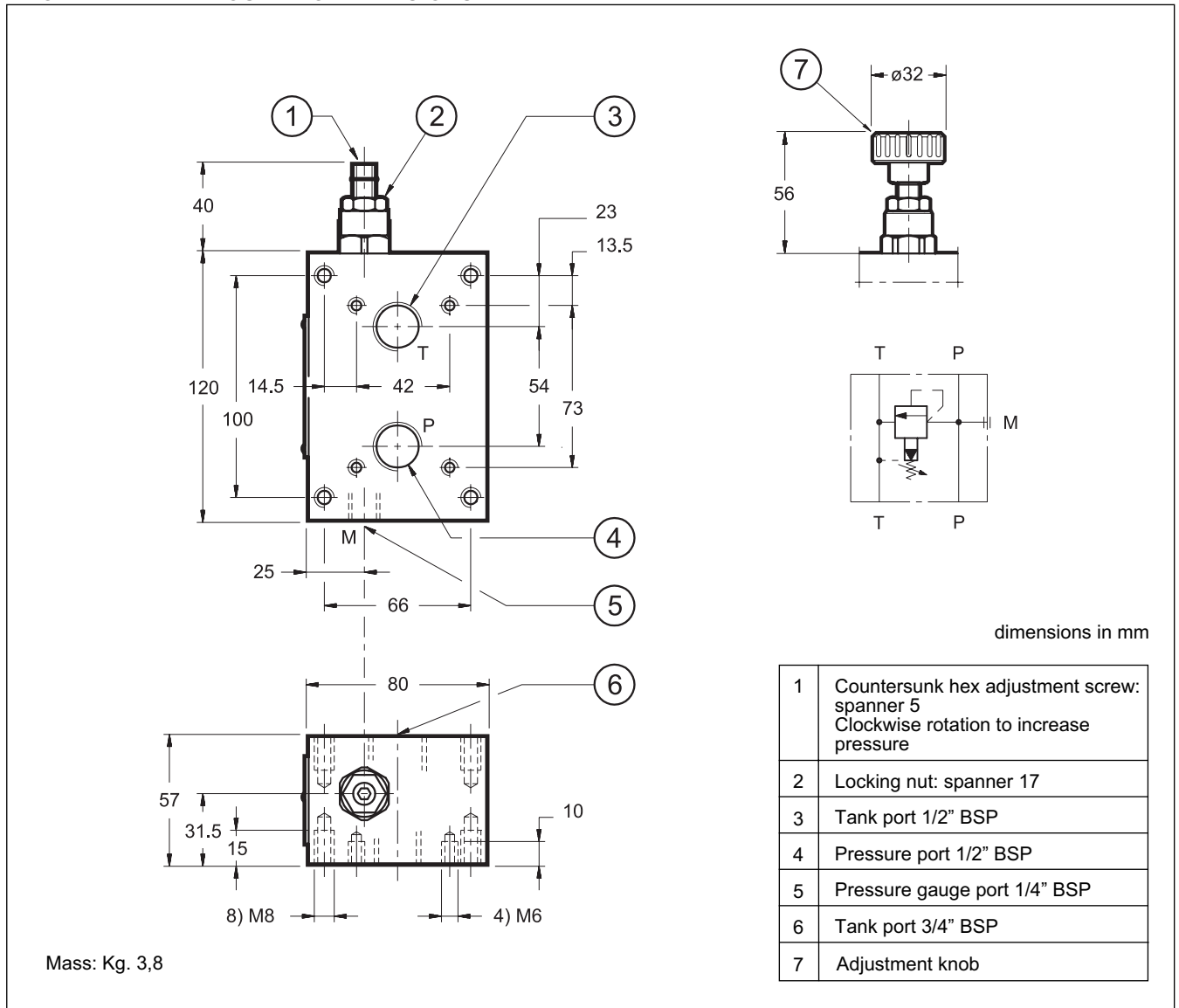



RM4*-MP

SERIES 30

1 - IDENTIFICATION CODE

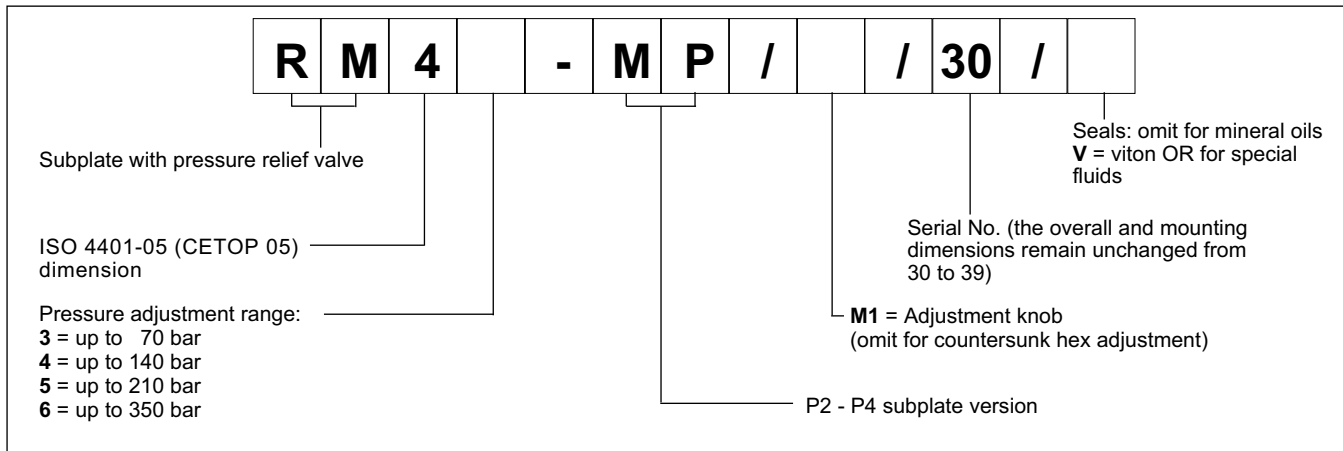

2 - CHARACTERISTIC CURVES (values obtained with viscosity of 36 cSt at 50°C)

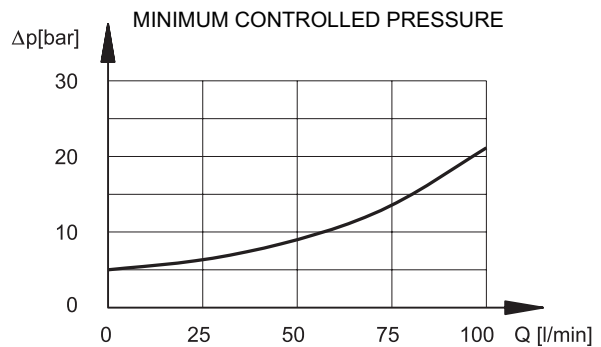
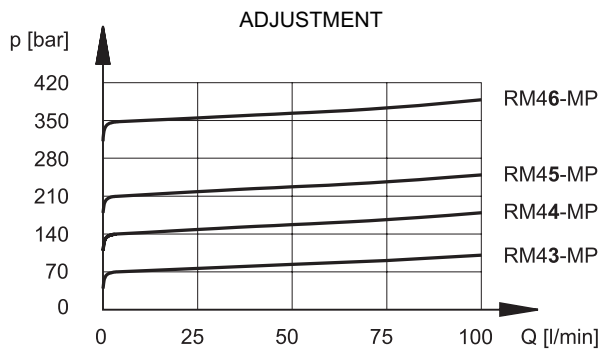

3 - HYDRAULIC FLUIDS

Use mineral oil-based hydraulic fluids HL or HM type, according to ISO 6743-4. For these fluids, use NBR seals. For fluids HFDR type (phosphate esters) use FPM seals (code V). For the use of other kinds of fluid such as HFA, HFB, HFC, please consult our technical department. Using fluids at temperatures higher than 80 °C causes a faster degradation of the fluid and of the seals characteristics. The fluid must be preserved in its physical and chemical characteristics.

 DIPLOMATIC HYDRAULICS	<p>DIPLOMATIC OLEODINAMICA SpA</p> <p>20025 LEGNANO (MI) - P.le Bozzi, 1 / Via Edison Tel. 0331/472111-472236 - Fax 0331/548328</p>
--	---