



DSH*

LEVER OPERATED DIRECTIONAL CONTROL VALVE

MOUNTING SURFACES

DSH3 ISO 4401-03 (CETOP 03)

DSH5 ISO 4401-05 (CETOP R05)

p max (see performances table)

Q nom (see performances table)

MOUNTING INTERFACE DSH3

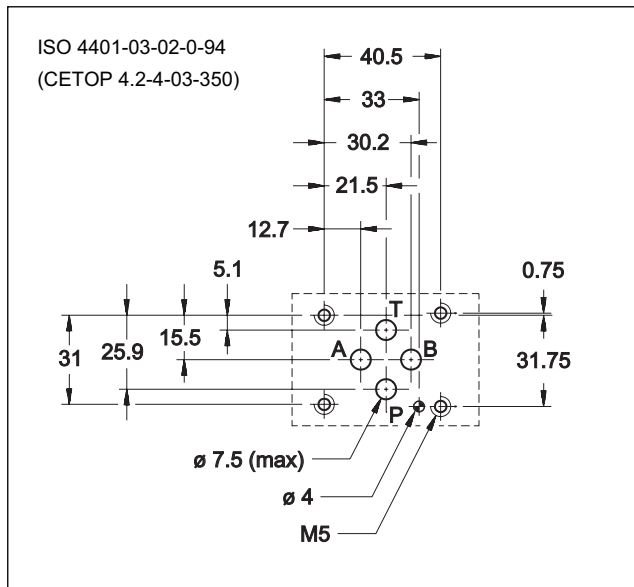

MOUNTING INTERFACE DSH5

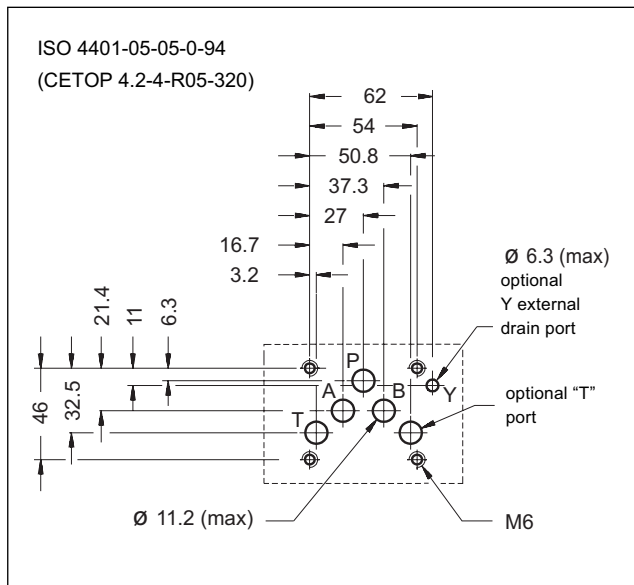

OPERATING PRINCIPLE

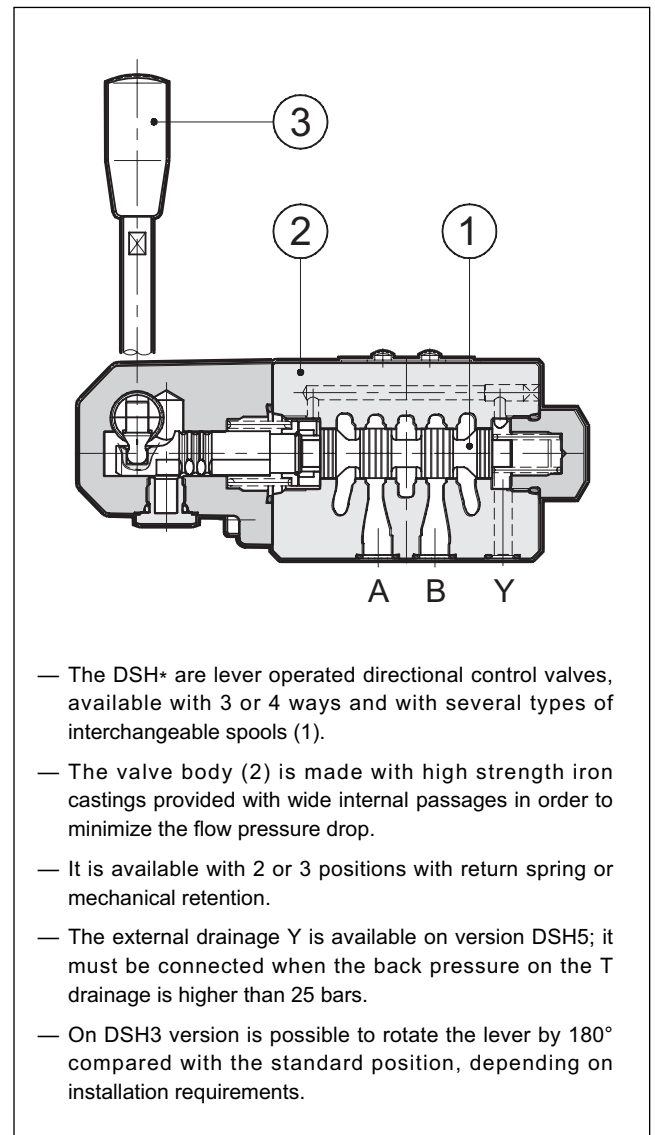



1 - IDENTIFICATION CODE

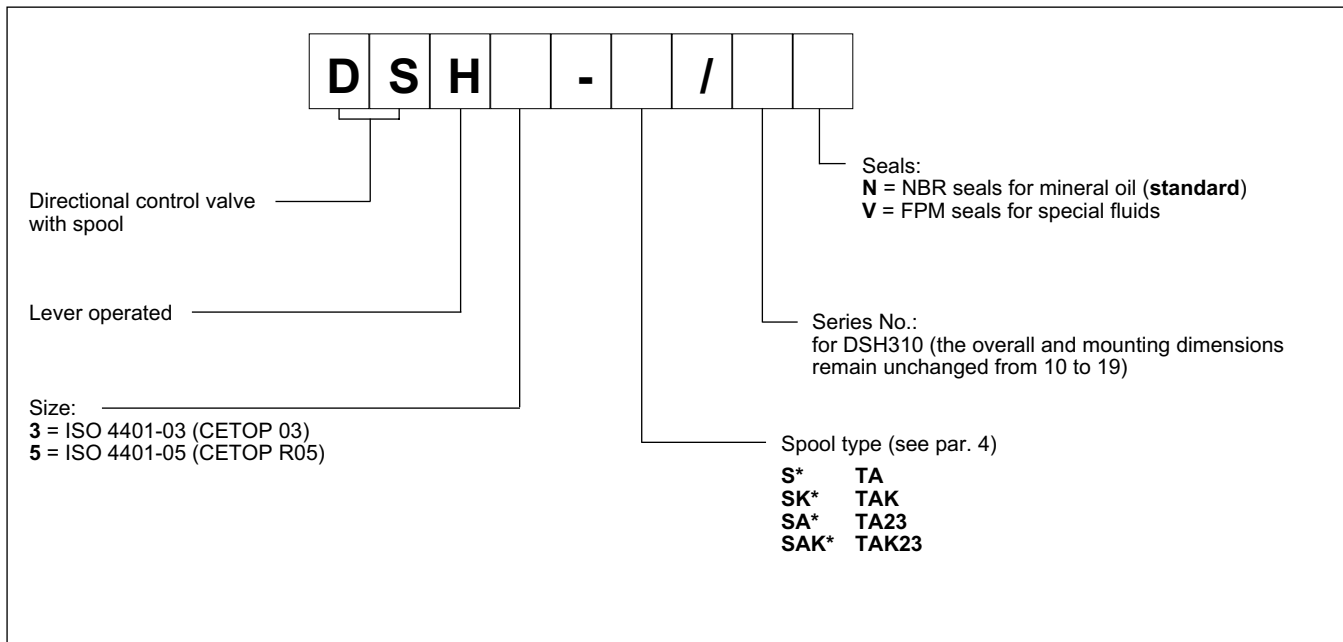

2 - PERFORMANCES (with mineral oil of viscosity of 36 cSt at 50°C)

		DSH3	DSH5
Maximum working pressure:	bar	350 25	320 25 320
- P A B ports			
- T port without Y external drain (standard for DSH3)			
- T port with Y external drain (only for DSH5)			
Nominal flow rate	l/min	75	125
Ambient temperature range	°C	-20 / +50	
Fluid temperature range	°C	-20 / +80	
Fluid viscosity range	cSt	10 ÷ 400	
Recommended viscosity	cSt	25	
Fluid contamination degree		according to ISO 4406:1999 class 20/18/15	
Mass	kg	2,1	4,2

3 - HYDRAULIC FLUIDS

Use mineral oil-based hydraulic fluids HL or HM type, according to ISO 6743-4. For these fluids, use NBR seals (code N).

For fluids HFDR type (phosphate esters) use FPM seals (code V).

For the use of other fluid types such as HFA, HFB, HFC, please consult our technical department.

Using fluids at temperatures higher than 80 °C causes a faster degradation of the fluid and of the seals characteristics.

The fluid must be preserved in its physical and chemical characteristics.



4 - SPOOL TYPE

Type **S***:
3 positions
with spring centering

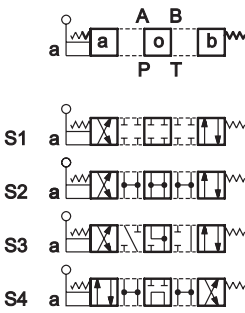

Type **SK***:
3 positions
with mechanical retention

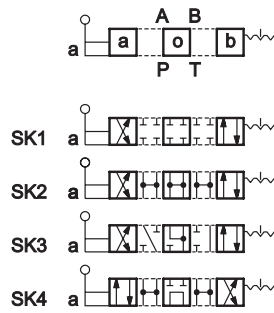

Type **SA***:
2 positions
(central + external)
with spring centering



Type **SAK***:
2 positions
(central + external)
with mechanical retention

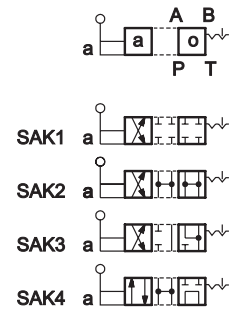

Type **TA**:
2 external positions
with return spring

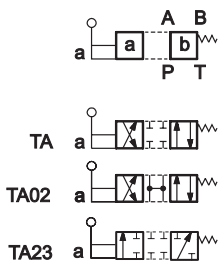

Type **TAK**:
2 external positions
with mechanical retention

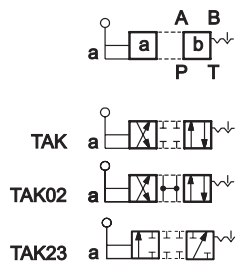

Besides the diagrams shown, which are the most frequently used, other special versions are available: consult our technical department for their identification and operating limits.



5 - PRESSURE DROPS Δp -Q (values obtained with viscosity 36 cSt at 50 °C)

5.1 - DSH3

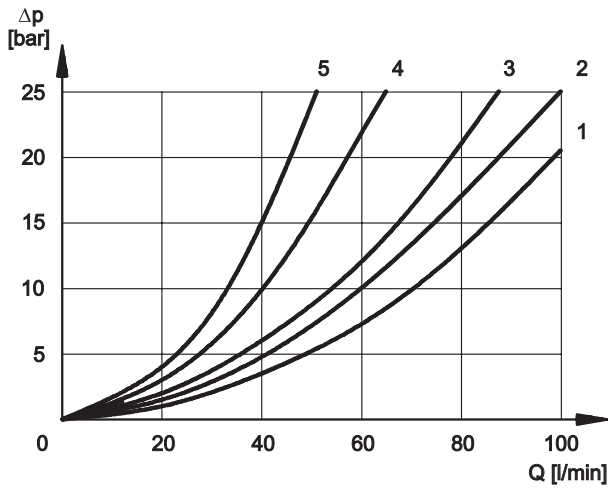

VALVE IN ENERGIZED POSITION

SPOOL TYPE	FLOW DIRECTION			
	P→A	P→B	A→T	B→T
CURVES ON GRAPH				
S1, SA1, SAK1	2	2	3	3
S2, SA2, SAK2	1	1	3	3
S3, SA3, SAK3	3	3	1	1
S4, SA4, SAK4	5	5	5	5
TA, TAK	2	2	2	2
TA02, TAK02	2	2	2	2
TA23, TAK23	3	3		

VALVE IN DE-ENERGIZED POSITION

SPOOL TYPE	FLOW DIRECTION				
	P→A	P→B	A→T	B→T	P→T
CURVES ON GRAPH					
S2, SA2, SAK2					2
S3, SA3, SAK3			3	3	
S4, SA4, SAK4					4

5.2 - DSH5

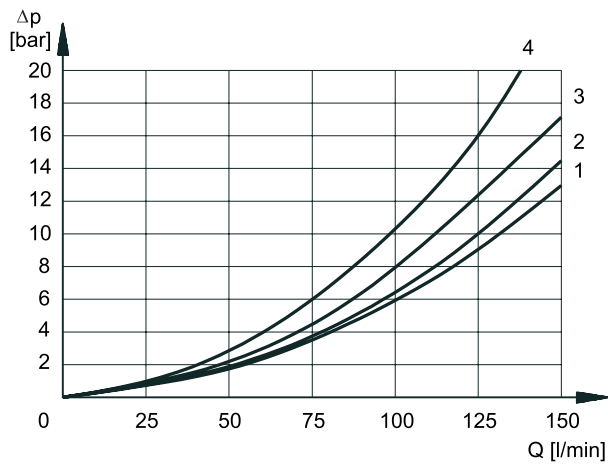

VALVE IN ENERGIZED POSITION

SPOOL TYPE	FLOW DIRECTION			
	P→A	P→B	A→T	B→T
CURVES ON GRAPH				
S1, SK1	2	2	1	1
S2, SK2	3	3	1	1
S3, SK3	3	3	2	2
S4, SK4	1	1	2	2
TA, TAK	3	3	2	2

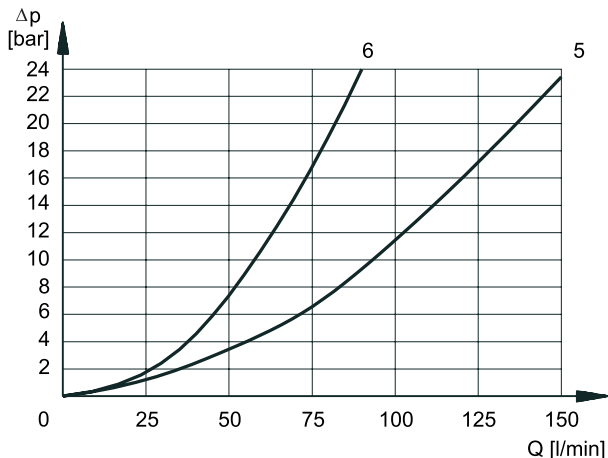

VALVE IN DE-ENERGIZED POSITION

SPOOL TYPE	FLOW DIRECTION				
	P→A	P→B	A→T	B→T	P→T
CURVES ON GRAPH					
S2, SK2					5
S3, SK3			6	6	
S4, SK4					5



6 - OPERATING LIMITS

The curves define the flow rate operating fields according to the valve pressure of the different versions. The values have been obtained according to ISO 6403 norm, with mineral oil viscosity 36 cSt at 50 °C and filtration ISO 4406:1999 class 18/16/13.

6.1 - DSH3

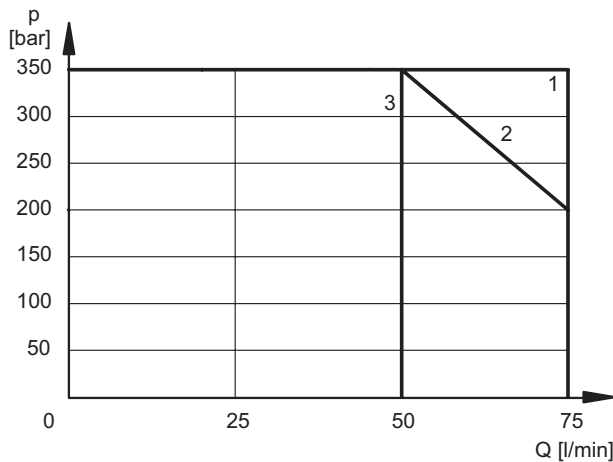

SPOOL TYPE	CURVE	
	P→A	P→B
S1, SA1, SAK1	1	1
S2, SA2, SAK2	1	1
S3, SA3, SAK3	2	2
S4, SA4, SAK4	3	3

SPOOL TYPE	CURVE	
	P→A	P→B
TA, TAK	1	1
TA02, TAK02	1	1
TA23, TAK23	1	1

6.2 - DSH5

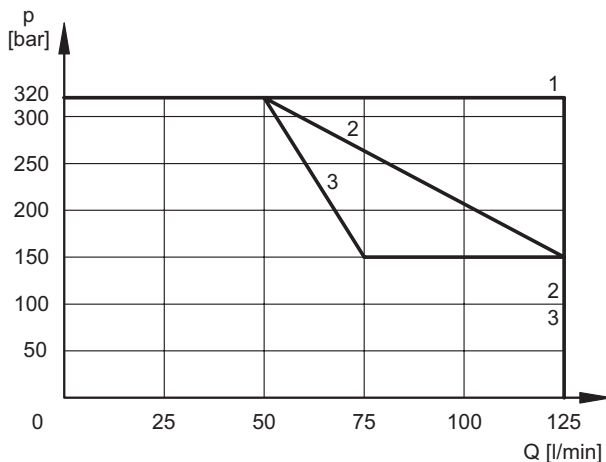

SPOOL TYPE	CURVE	
	P→A	P→B
S1, SK1	1	1
S2, SK2	1	1
S3, SK3	1	1
S4	3	3
SK4	2	2

SPOOL TYPE	CURVE	
	P→A	P→B
TA, TAK	1	1

NOTE: The values indicated in the graphs are relevant to the standard valve. The operating limits can be considerably reduced if a 4-way valve is used with port A or B plugged.

7 - INSTALLATION

Configurations with centering and return springs can be mounted in any position; valves with mechanical detent must be mounted with the longitudinal axis horizontal. Valve fixing is by means of screws or tie rods, with the valve mounted on a lapped surface, with values of planarity and smoothness that are equal to or better than those indicated in the drawing. If the minimum values of planarity and/or smoothness are not met, fluid leakage between valve and mounting surface can easily occur.

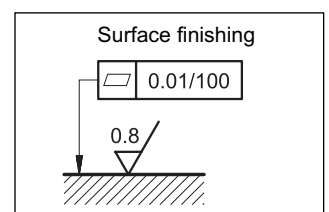



8 - OVERALL AND MOUNTING DIMENSIONS DSH3

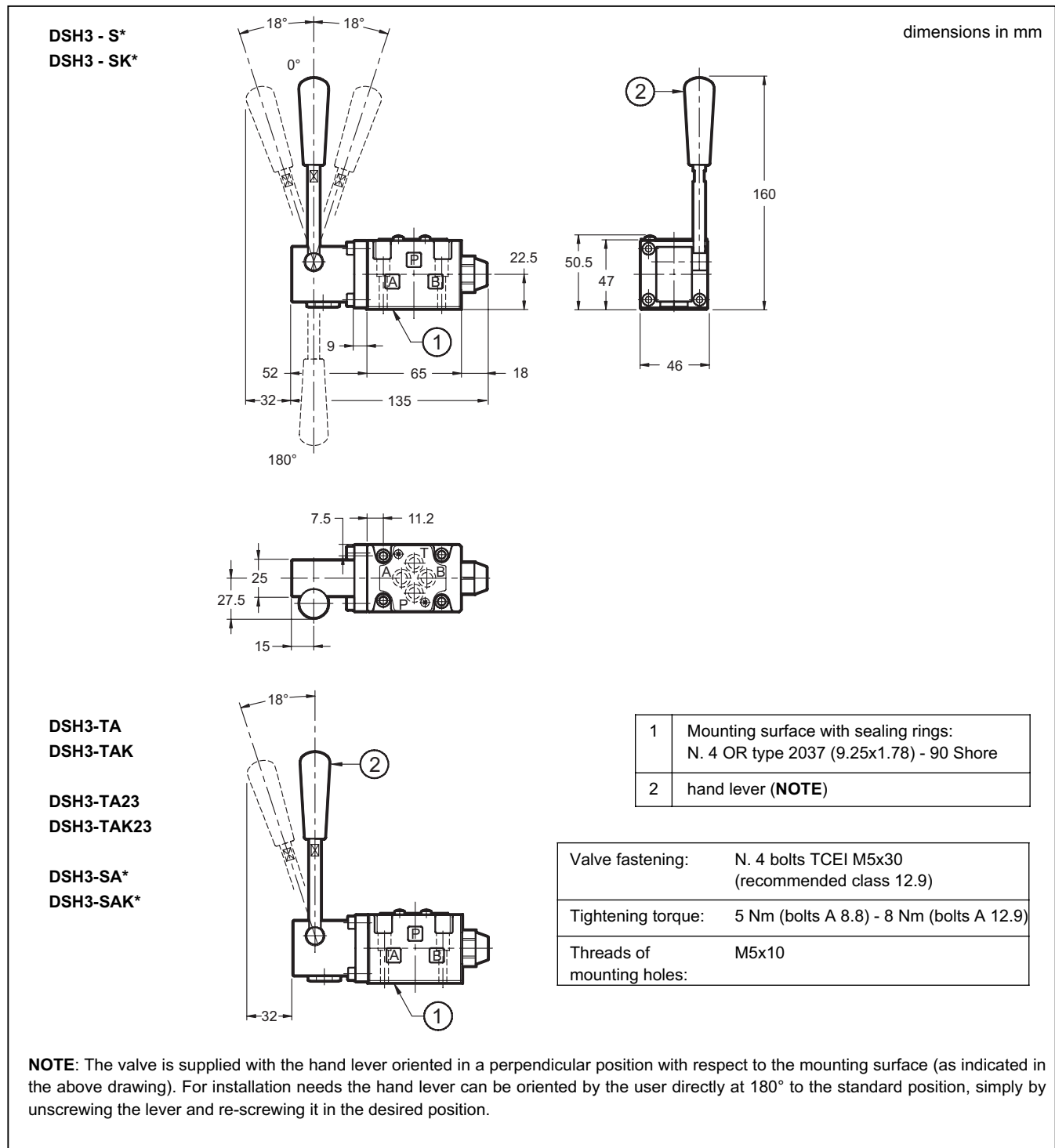



9 - OVERALL AND MOUNTING DIMENSIONS DSH5

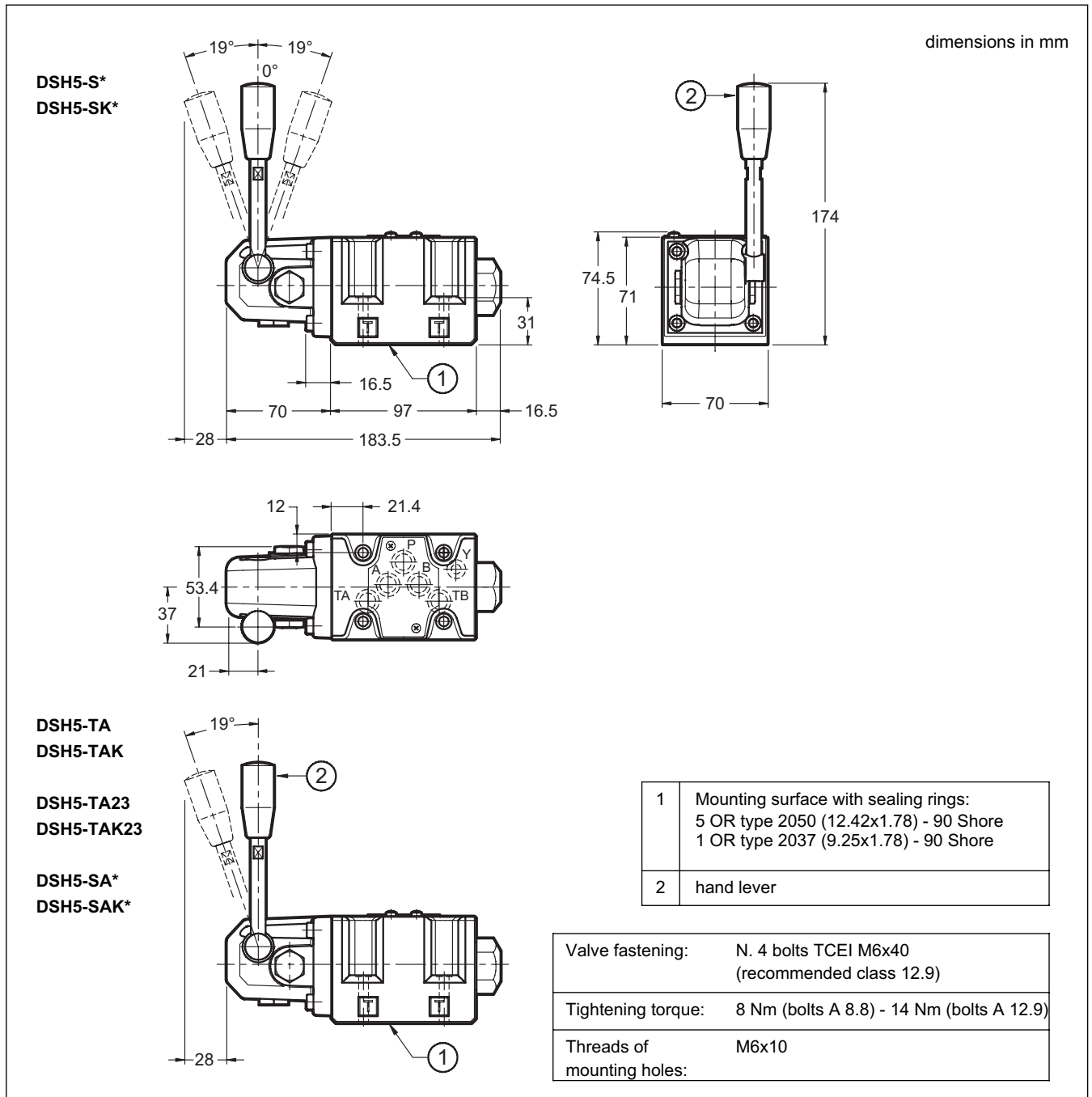

10 - SUBPLATES (See catalogue 51 000)

	DSA3	DSA5
Type with rear ports	PMMD-AI3G	PMD4-AI4G
Type with side ports	PMMD-AL3G	PMD4-AL4G
Threading of ports P, T, A, B,	3/8" BSP	1/2" BSP



DSH*



DIPLOMATIC OLEODINAMICA SpA
20025 LEGNANO (MI) - P.le Bozzi, 1 / Via Edison
Tel. 0331/472111 - Fax 0331/548328