



**DIPLOMATIC  
HYDRAULICS**

41 310/108 ED

# DS5

## SOLENOID OPERATED DIRECTIONAL CONTROL VALVE



### SUBPLATE MOUNTING ISO 4401-05 (CETOP 05)

**p** max 320 bar  
**Q** max 150 l/min

### MOUNTING INTERFACE

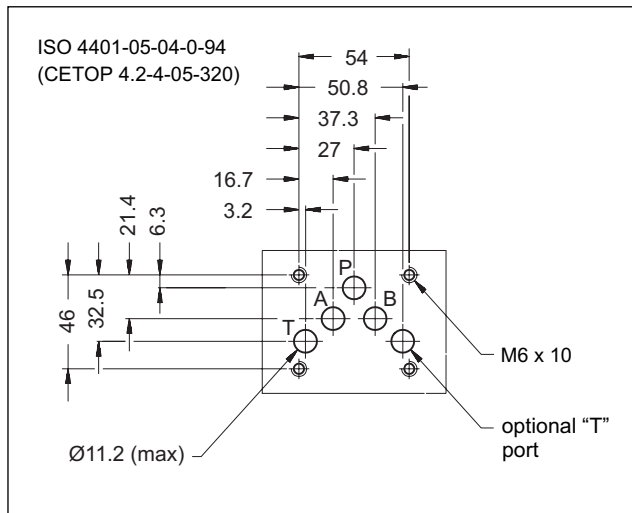

### PERFORMANCE RATINGS (with mineral oil of viscosity of 36 cSt at 50°C)

	bar	DC	AC
		320	
Maximum operating pressure P - A - B ports		210	140
T port	standard version	320	-
	version with Y port		
Maximum flow rate	l/min	150	120
Pressure drop $\Delta p$ -Q	see paragraph 4		
Operating limits	see paragraph 6		
Electrical features	see paragraph 7		
Electrical connections	plug for connector DIN 43650		
Ambient temperature range	°C	-20 / +50	
Fluid temperature range	°C	-20 / +80	
Fluid viscosity range	cSt	10 ÷ 400	
Recommended viscosity	cSt	25	
Fluid contamination degree	according to ISO 4406:1999 class 20/18/15		
Mass:	single solenoid valve	kg	4,4
	double solenoid valve	kg	5,9
			3,6
			4,3

### OPERATING PRINCIPLE

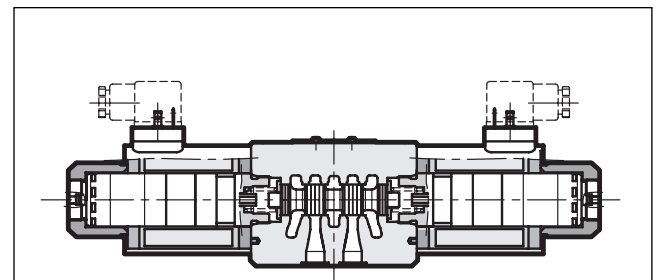

- Direct acting, subplate mounting directional control valve, with mounting surface according to ISO 4401 (CETOP RP121H).
- The valve body is made with high strength iron castings provided with wide internal passages in order to minimize the flow pressure drop. Wet armature solenoids with interchangeable coils are used (for further information on solenoids see paragraph 7).
- The valve is supplied with 3 or 4 way designs and with several interchangeable spools with different porting arrangements.
- The valve is available with DC or AC solenoids. DC solenoids can also be fed with AC power supply, by using connectors with a built-in rectifier bridge (see cat. 49 000).
- The DC solenoids DS5 directional valve is available in the following special versions:
  - version with Y external subplate drain port, (see paragraph 12.1).
  - version with soft-shifting (see paragraph 12.4)
  - version with adjustable "soft-shifting" device (see paragraph 12.5)



## 1 - IDENTIFICATION CODE

	<b>D</b>	<b>S</b>	<b>5</b>	<b>-</b>		<b>/</b>	<b>12</b>	<b>-</b>		<b>K1</b>	<b>/</b>	
--	----------	----------	----------	----------	--	----------	-----------	----------	--	-----------	----------	--

Solenoid operated directional control valve

ISO 4401-05 (CETOP 05) size

Spool type (see par. 3)

<b>S*</b>	<b>TA</b>
<b>SA*</b>	<b>TB</b>
<b>SB*</b>	<b>RK</b>

Series: (the overall and mounting dimensions remain unchanged from 10 to 19)

Seals:  
**N** = NBR seals for mineral oil (**standard**)  
**V** = FPM seals for special fluids

Manual override: omit for override integrated in the tube (**standard**)  
**CM** = manual override, boot protected (only for DC version)

Coil electrical connection: plug for connector type DIN 43650 (**standard**)

DC power supply

**D12** = 12 V  
**D24** = 24 V  
**D110** = 110 V  
**D220** = 220 V  
**D00** = valve without coils (see NOTE)

AC power supply

**A24** = 24 V - 50 Hz  
**A48** = 48 V - 50 Hz  
**A110** = 110 V - 50 Hz / 120 V - 60 Hz  
**A230** = 230 V - 50 Hz / 240 V - 60 Hz  
**A00** = valve without coils (see NOTE)

**F110** = 110 V - 60 Hz  
**F220** = 220 V - 60 Hz

**NOTE:** The locking rings of the coils and the relevant O-Rings are supplied together with valves

## 2 - HYDRAULIC FLUIDS

Use mineral oil-based hydraulic fluids HL or HM type, according to ISO 6743-4. For these fluids, use NBR seals (code N).  
 For fluids HFDR type (phosphate esters) use FPM seals (code V).  
 For the use of other fluid types such as HFA, HFB, HFC, please consult our technical department.

Using fluids at temperatures higher than 80 °C causes a faster degradation of the fluid and of the seals characteristics.  
 The fluid must be preserved in its physical and chemical characteristics.



## 3 - SPOOL TYPE

**Type S\*:**  
2 solenoids - 3 positions  
with spring centering

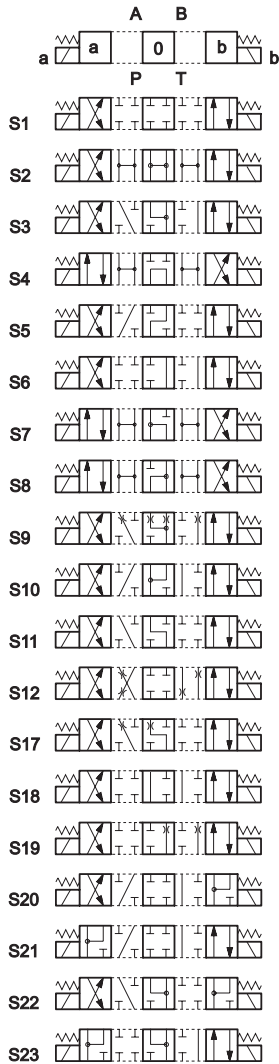

**Type RK:**  
2 solenoids - 2 positions  
with mechanical retention

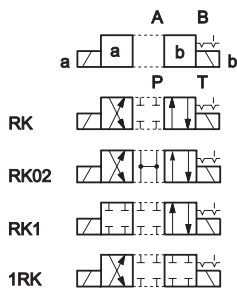

**Type SA\*:**  
1 solenoid side A  
2 positions (central + external)  
with spring centering

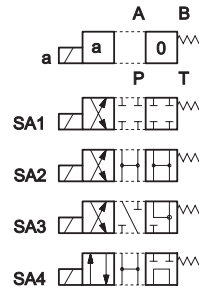

**Type TA:**  
1 solenoid side A  
2 external positions  
with return spring

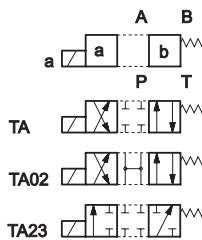

**Type SB\*:**  
1 solenoid side B  
2 positions (central + external)  
with spring centering

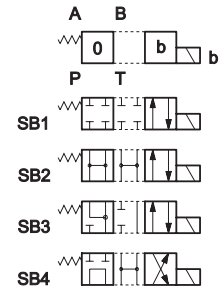

**Type TB:**  
1 solenoid side B  
2 external positions  
with return spring

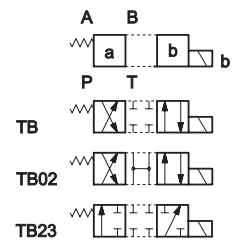

Besides the diagrams shown, which are the most frequently used, other special versions are available: consult our technical department for their identification, feasibility and operating limits.



## 4 - PRESSURE DROPS $\Delta p$ -Q (obtained with viscosity 36 cSt at 50 °C)

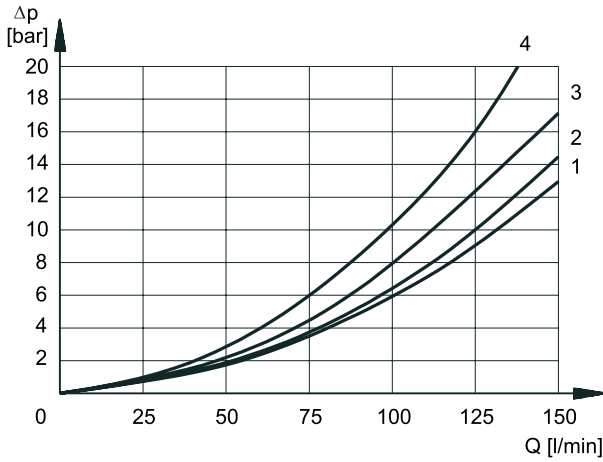

### PRESSURE DROPS WITH VALVE ENERGIZED

SPOOL TYPE	FLOW DIRECTION			
	P-A	P-B	A-T	B-T
	CURVES ON GRAPH			
S1, SA1, SB1	2	2	1	1
S2, SA2, SB2	3	3	1	1
S3, SA3, SB3	3	3	2	2
S4, SA4, SB4	1	1	2	2
S5	2	1	1	1
S6, S11	3	3	2	2
S7, S8	1	1	2	2
S9	3	3	2	2
S10	1	1	1	1
S12	2	2	1	1
S17, S19	2	2	1	1
S18	1	2	1	1
S20, S21				
S22, S23				
TA, TB	3	3	2	2
TA02, TB02	3	3	2	2
TA23, TB23	4	4		
RK	3	3	2	2
RK02	3	3	2	2
RK1, 1RK	3	3	2	2

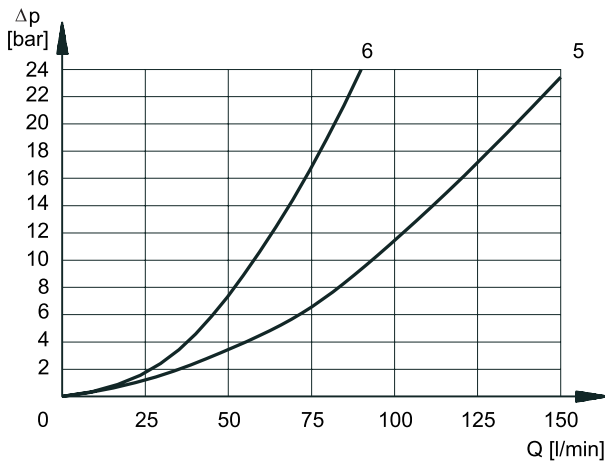

### PRESSURE DROPS WITH VALVE IN DE-ENERGIZED POSITION

SPOOL TYPE	FLOW DIRECTION				
	P-A	P-B	A-T	B-T	P-T
	CURVES ON GRAPH				
S2, SA2, SB2					5
S3, SA3, SB3			6	6	
S4, SA4, SB4					5
S5		3			
S6				6	
S7					5
S8					5
S10	3	3			
S11			6		
S18	3				
S22					
S23					

## 5 - SWITCHING TIMES

The values indicated are obtained according to ISO 6403 standard, with mineral oil viscosity 36 cSt at 50°C.

SOLENOID TYPE	TIMES	
	ENERGIZING	DE-ENERGIZING
DC	100 ÷ 150 ms	20 ÷ 50 ms
AC	15 ÷ 30 ms	20 ÷ 50 ms



## 6 - OPERATING LIMITS

The curves define the flow rate operating fields according to the valve pressure of the different versions.

The values have been obtained according to ISO 64003 norm with solenoids at rated temperature and supplied with voltage equal to 90% of the nominal voltage.

The values have been obtained with mineral oil, viscosity 36 cSt, temperature 50 °C and filtration according to ISO 4406:1999 class 18/16/13.

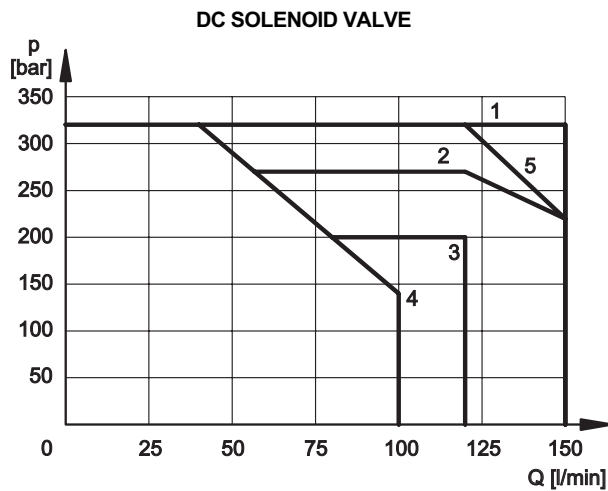

SPOOL TYPE	CURVE	
	P-A	P-B
S1, SA1, SB1	1	1
S2, SA2, SB2	1	1
S3, SA3, SB3	2	2
S4, SA4, SB4	3	3
S5	1	1
S6	2	1
S7	4	4
S8	4	4
S9	1	1
S10	1	1
S11	1	2
S12	1	1

SPOOL TYPE	CURVE	
	P-A	P-B
S17	1	3
S18	1	1
S19	3	1
S20		
S21		
S22		
S23		
TA, TB	5	5
TA02, TB02	3	3
TA23, TB23	1	1
RK	1	1
RK02	1	1
RK1, 1RK	1	1

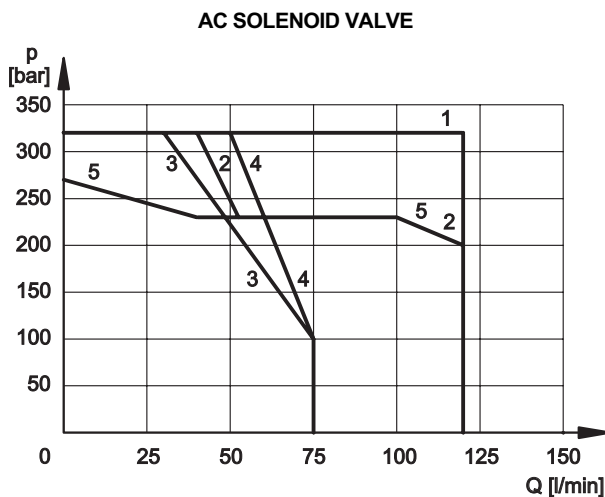

SPOOL TYPE	CURVE	
	P-A	P-B
S1, SA1, SB1	1	1
S2, SA2, SB2	2	2
S3, SA3, SB3	2	2
S4, SA4, SB4	4	4
S5	1	1
S6	2	1
S7	3	3
S8	3	3
S9	2	2
S10	1	1
S11	1	2
S12	1	1

SPOOL TYPE	CURVE	
	P-A	P-B
S17	1	5
S18	1	1
S19	5	1
S20		
S21		
S22		
S23		
TA, TB	1	1
TA02, TB02	5	5
TA23, TB23	1	1
RK	1	1
RK02	1	1
RK1, 1RK	1	1

**NOTE:** The values indicated in the graphs are relevant to the standard solenoid valve. The operating limits can be considerably reduced if a 4-way valve is used with port A or B plugged.

For flow and pressure performances of soft-shifting configuration (options F) see par. 12.5

Flow and pressure performances of adjustable soft-shifting device configurations (options S) are influenced by the set shifting time.



## 7 - ELECTRICAL FEATURES

### 7.1 Solenoids

These are essentially made up of two parts: tube and coil. The tube is threaded into the valve body and includes the armature that moves immersed in oil, without wear. The inner part, in contact with the oil in the return line, ensures heat dissipation.

The coil is fastened to the tube by a threaded ring, and can be rotated, to suit the available space.

**NOTE 1:** In order to further reduce the emissions, use of type H connectors is recommended. These prevent voltage peaks on opening of the coil supply electrical circuit (see CAT. 49 000).

<b>SUPPLY VOLTAGE FLUCTUATION</b>	± 10% Vnom
<b>MAX SWITCH ON FREQUENCY</b>	15.000 ins/hr
<b>DUTY CYCLE</b>	100%
<b>ELECTROMAGNETIC COMPATIBILITY (EMC)</b> emissions (see <b>NOTE 1</b> ) immunity	EN 50081-1 EN 50082-2 in compliance with 89/336 EEC
<b>LOW VOLTAGE</b>	in compliance with 73/23/EEC 96/68/EEC
<b>CLASS OF PROTECTION:</b> Atmospheric agents (CEI EN 60529) Coil insulation (VDE 0580) Impregnation	IP 65 (see <b>NOTE 2</b> ) class H class F

**NOTE 2:** The IP65 protection degree is guaranteed only with the connector correctly connected and installed.

### 7.2 Current and absorbed power for DC solenoid valve

The table shows current and power consumption values relevant to the different coil types for DC.

The rectified current supply takes place by fitting the valve with an alternating current source (50 or 60 Hz), rectified by means of a bridge built-in to the "D" type connectors (see cat. 49 000).

#### Coils for direct current (values ± 5%)

Suffix	Nominal voltage [V]	Resistance at 20°C [Ω]	Current consumpt. [A]	Power consumpt. [W]	Coil code
<b>D12</b>	12	3 - 3,4	3,81	45,8	1902870
<b>D24</b>	24	12 - 14	1,90	45,3	1902871
<b>D110</b>	110	235-270	0,44	48,4	1902872
<b>D220</b>	220	960-1110	0,21	47,1	1902873

**NOTE:** It is necessary to allow, when supplying the valve with rectified current, a reduction of the operating limits by 5-10% approx.

### 7.3 Current and absorbed power for AC solenoid valve

The table shows current and power consumption values at inrush and at holding, relevant to the different coil types for AC current.

#### Coils for alternating current (values ± 5%)

Suffix	Nominal voltage [V]	Frequency [Hz]	Resistance at 20°C [ohm]	Current consumption at inrush [A]	Current consumption at holding [A]	Power consumption at inrush [VA]	Power consumption at holding [VA]	Coil code
<b>A24</b>	24	50	0,53	25	3,96	600	95	1902890
<b>A48</b>	48		2,09	12,5	2,3	600	110	1902891
<b>A110</b>	110V-50Hz	50/60	10,9	5,2	0,96	572	105	1902892
	120V-60Hz		10,9	5,2	0,89	572	105	
<b>A230</b>	230V-50Hz		52,7	2,8	0,46	644	105	1902893
	240V-60Hz		52,7	2,8	0,38	644	105	
<b>F110</b>	110	60	8,80	5,2	0,95	572	105	1902894
<b>F220</b>	220		35,2	2,7	0,48	594	105	1902895

## 8 - INSTALLATION

Configurations with centering and return springs can be mounted in any position; type RK valves - without springs and with mechanical detent - must be mounted with the longitudinal axis horizontal. Valve fixing is by means of screws or tie rods, with the valve mounted on a lapped surface, with values of planarity and smoothness that are equal to or better than those indicated in the drawing. If the minimum values of planarity and/or smoothness are not met, fluid leakage between valve and mounting surface can easily occur.

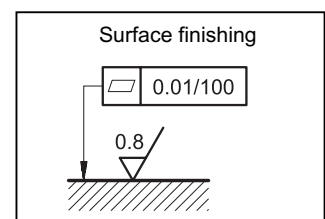

## 9 - ELECTRIC CONNECTORS

**The solenoid valves are not supplied with connector. Connectors must be ordered separately.**

For the identification of the connector type to be ordered, please see catalogue 49 000.



## 10 - OVERALL AND MOUNTING DIMENSIONS FOR DC SOLENOID VALVES

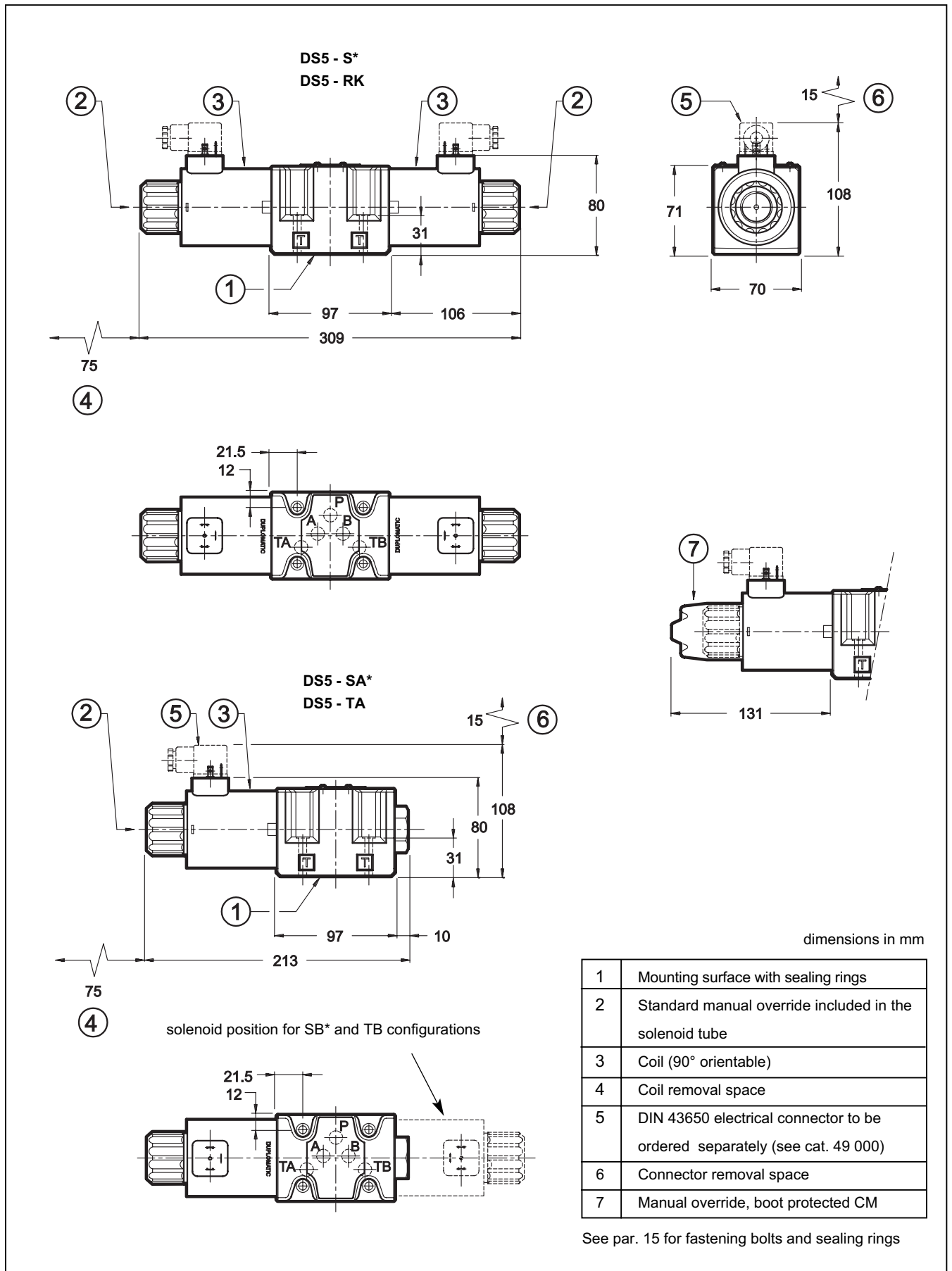



## 11 - OVERALL AND MOUNTING DIMENSIONS FOR AC SOLENOID VALVES

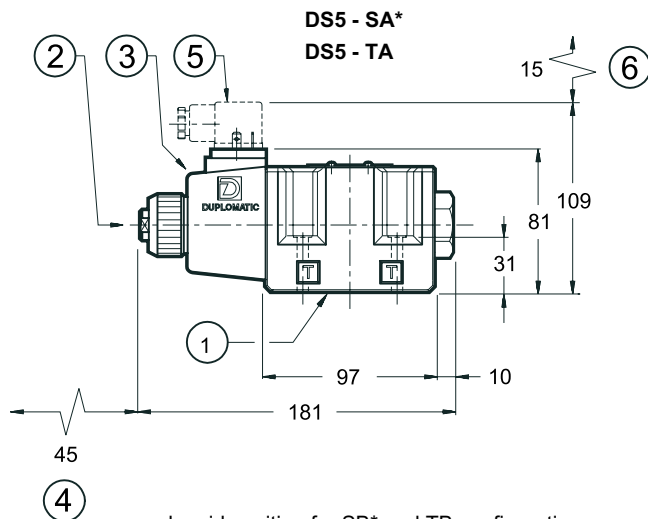
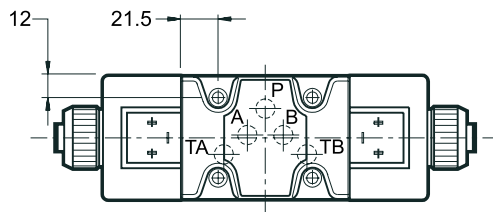
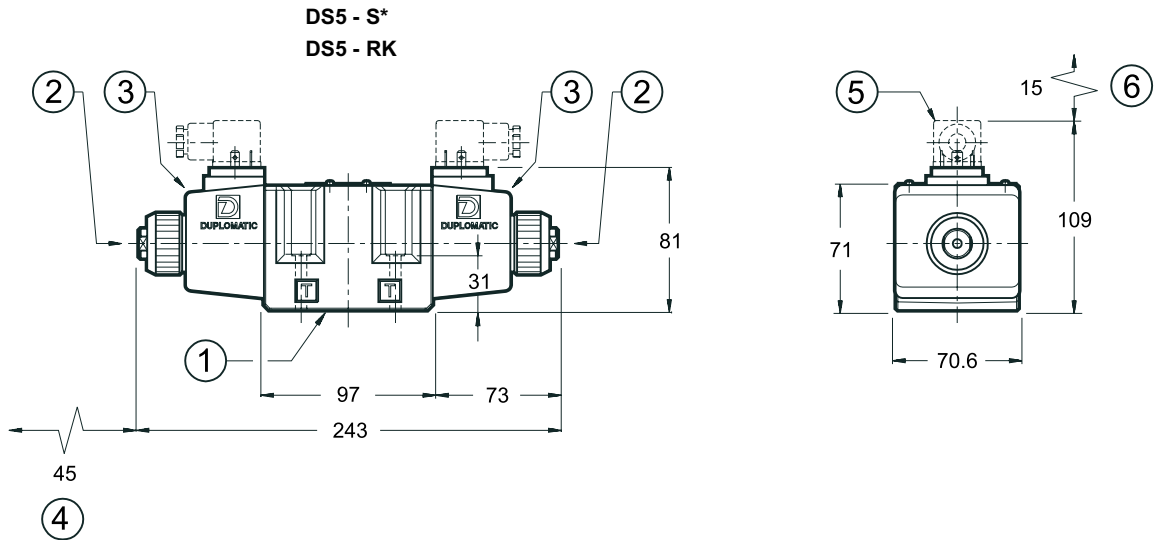

solenoid position for SB\* and TB configurations

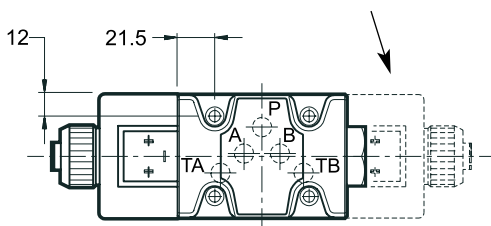

dimensions in mm

1	Mounting surface with sealing rings
2	Standard manual override included in the solenoid tube
3	Coil (360° orientable)
4	Coil removal space
5	DIN 43650 electrical connector to be ordered separately (see cat. 49 000)
6	Connector removal space

See par. 15 for fastening bolts and sealing rings



## 12 - SPECIAL VERSIONS FOR DC SOLENOID VALVE

### 12.1 - Identification code for external drain version

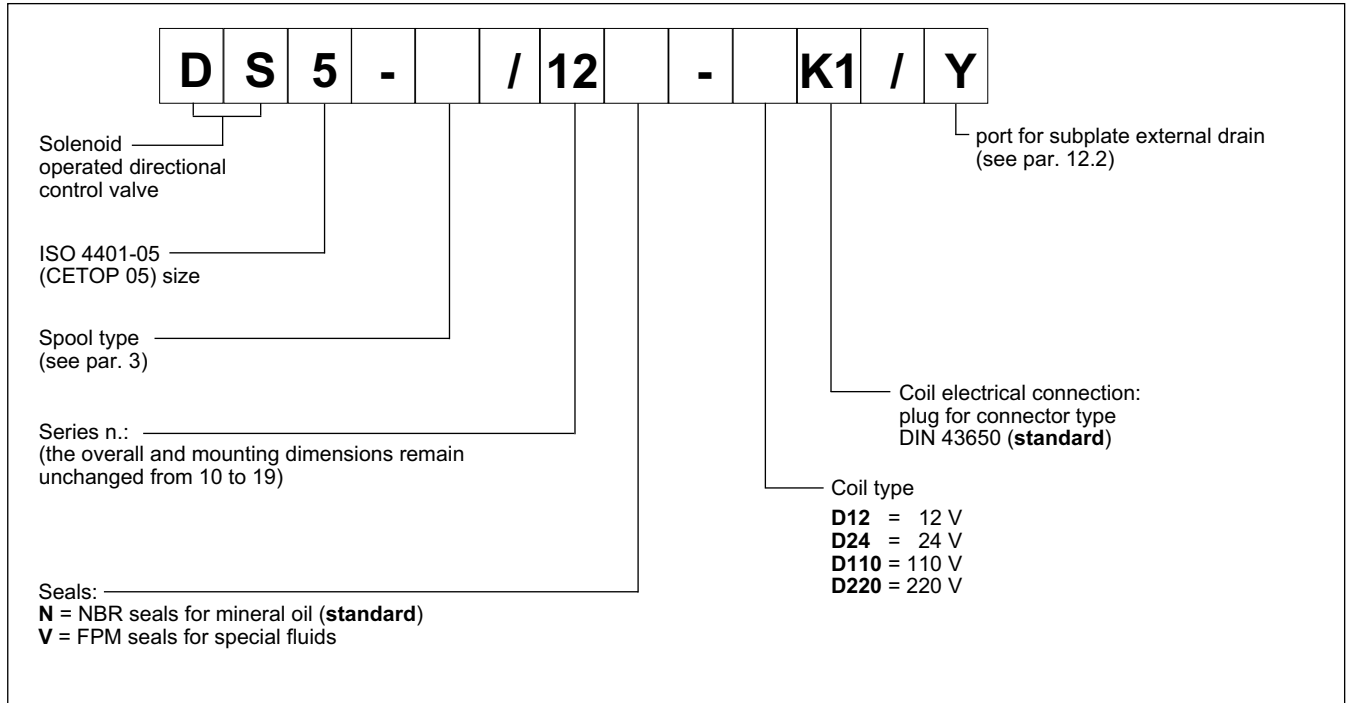

### 12.2 - Subplate external drain port (option Y)

This version allows the operation with pressures up to 320 bar on the valve T port.

It is a drain port Y realized on the valve mounting interface in compliance with ISO 4401-05-05-0-94 (CETOP 4.2-4-R05). The Y port is connected with the solenoid chamber: in this way the tubes are not stressed by the pressure operating on the valve T port.

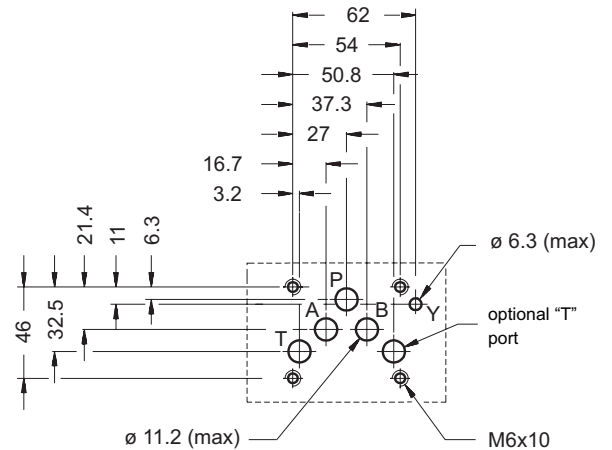



## 12.2 - Identification code for soft-shifting versions

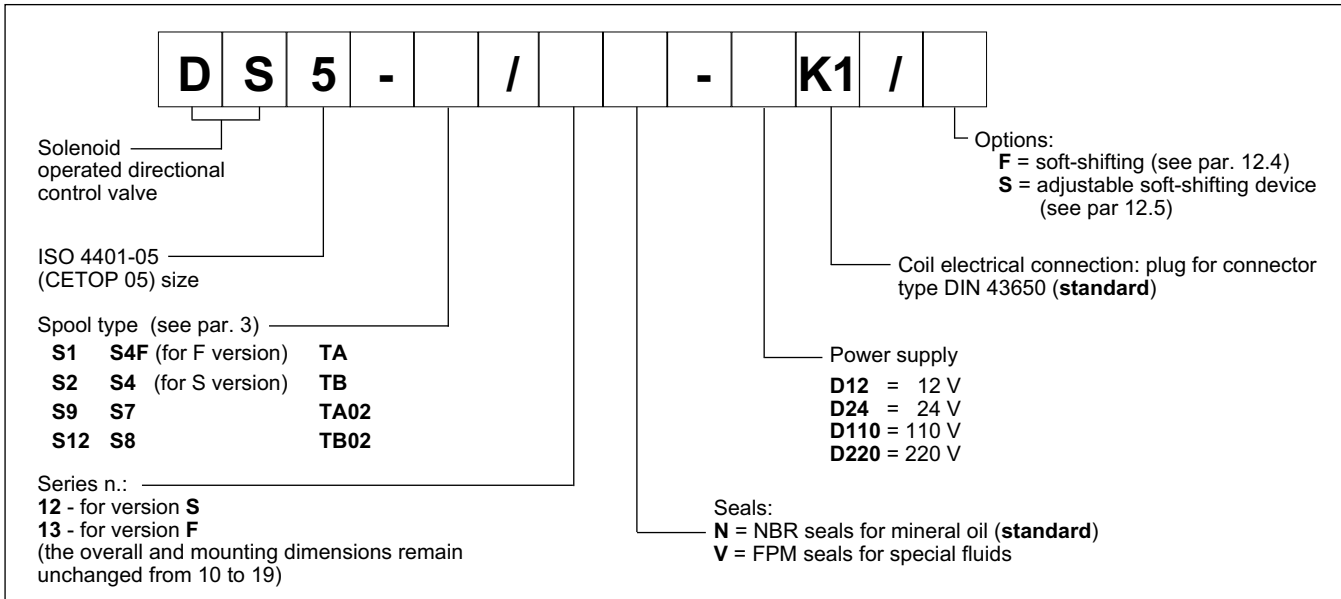

## 12.4 - Fixed restrictor for soft-shifting (option F)

This version enables hydraulic actuators to perform a smooth start and stop by reducing the speed of movement of the valve spool.

The diagram on the side shows the operating limits of the spools available in the soft-shifting version (**NOTE**: for this version, the S9 spool must be used instead of the S3 one).

The table on the side shows the switching times. The values indicated are obtained according to ISO 6403 standard, with mineral oil viscosity 36 cSt at 50°C.

The shifting time and characteristics curves, are influenced by the viscosity (and thus by the temperature) of the operating fluid. Moreover, times can vary according to the flow rate and operating pressure values of the valve.

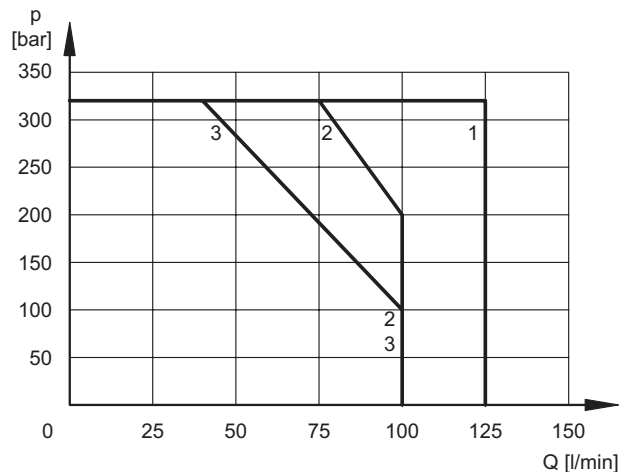

SPOOL TYPE	CURVE		TIMES	
	P-A	P-B	ENERGIZING	DE-ENERGIZING
S1, S12	1	1	300 ÷ 500	300 ÷ 500
S2	2	2	450	200 ÷ 300
S4F, S7, S8	3	3	400	400 ÷ 200
S9	1	1	300 ÷ 500	300 ÷ 500
TA, TB	2	2	300 ÷ 400	300 ÷ 400
TA02, TB02	2	2	400	200 ÷ 300

## 12.5 - Directional solenoid valve with adjustable "soft-shifting" device (option S)

This solenoid valve is supplied with a suitable device, adjustable by the user, which enables the control of the valve spool shifting time. In this way the hydraulic actuators can perform smooth movements, by controlling the valve switching time according to the machine cycle and the inertia of the moving parts.

**NOTE**: during the first start-up the valve body must be filled with the operating fluid through the tap (1).

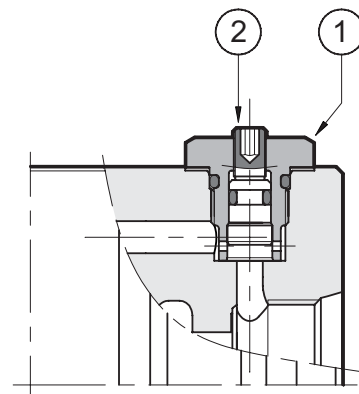

1	Plug spanner 17 mm - tightening torque 20 Nm
2	Shifting time adjustment screw countersunk hex spanner 2,5 mm



## 13 - SPARE PARTS FOR DC SOLENOID VALVE

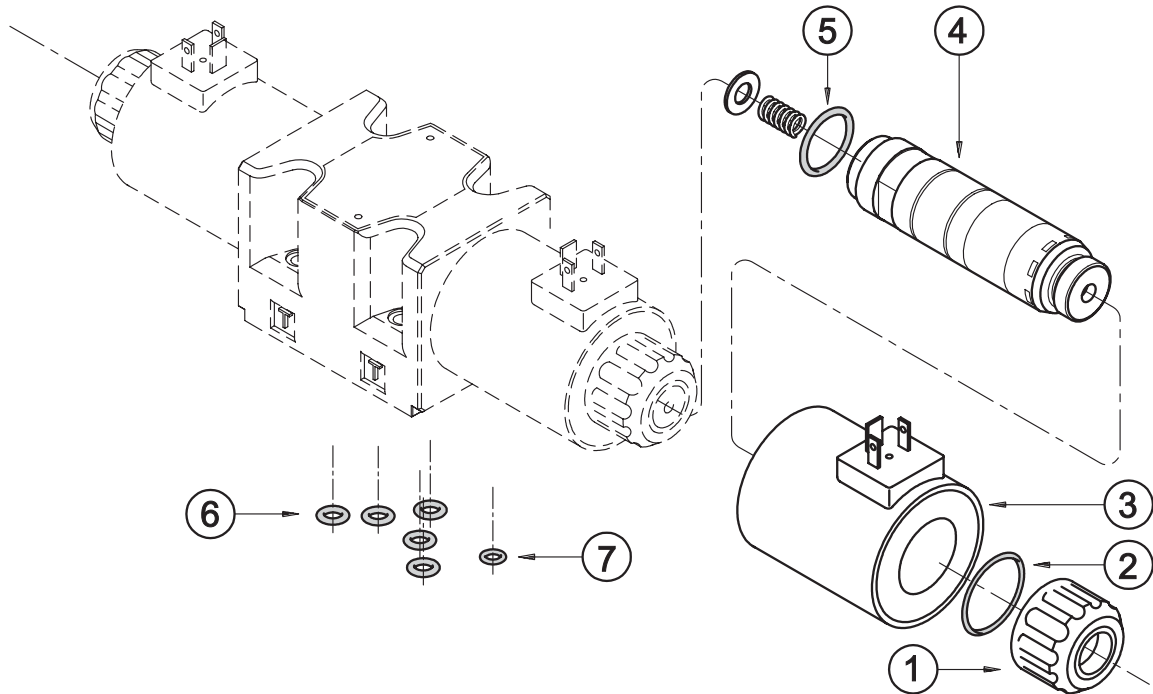

### DC COILS IDENTIFICATION CODE

**C31 - K1 / 20**

Supply voltage

**D12** = 12 V

**D24** = 24 V

**D110** = 110 V

**D220** = 220 V

Series no.:  
(the overall and mounting  
dimensions remain  
unchanged from 20 to 29)

plug for connector type  
DIN 43650 (**standard**)

1	Coil locking ring with seal included cod. 0119383
2	ORM type 0320 - 25 (32x2.5) - 70 Shore
3	Coil (see identification code)
4	Solenoid tube TD31-M27/20N (NBR seals) TD31-M27/20V (FPM seals) <b>NOTE:</b> the solenoid tube is supplied with OR n° 5.
5	OR type 3-912 (23.47x2.95) - 70 Shore
6	N. 5 OR type 2050 (12.42x1.78) - 90 Shore
7	For version with external subplate drain only (option Y): OR type 2037 (9.25x1.78) - 90 Shore

### SEALS KIT

The codes here below include O-Rings ref. 2, 5, 6 and 7.

**Cod. 1984418** NBR seals

**Cod. 1984419** FPM (viton) seals



## 14 - SPARE PARTS FOR AC SOLENOID VALVE

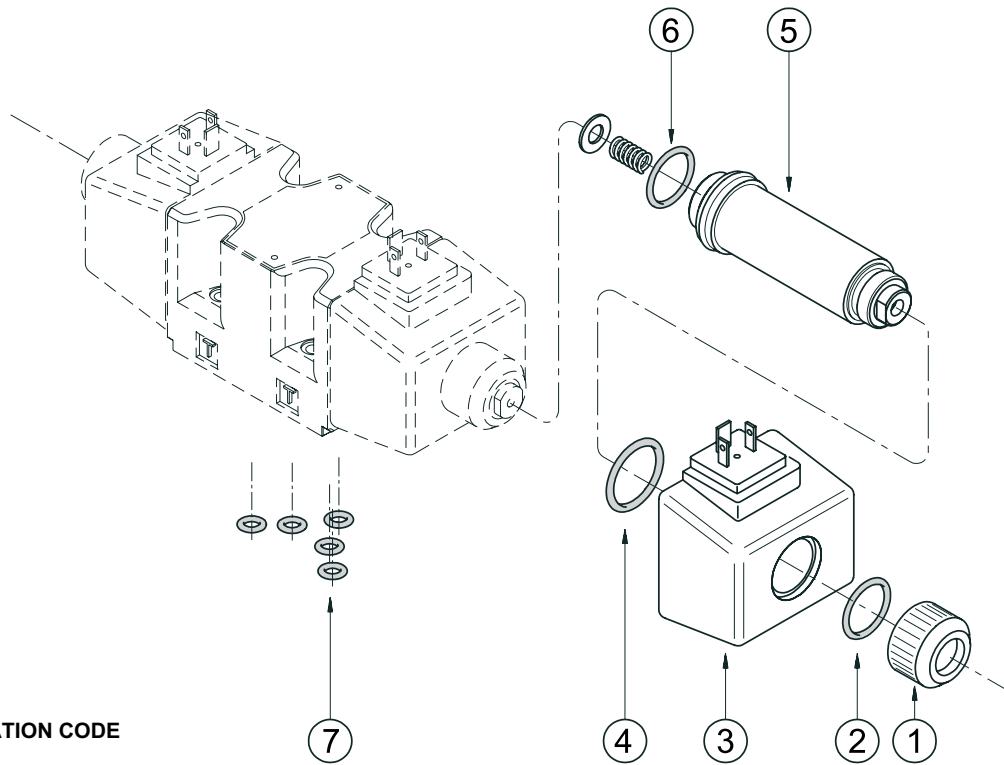

### AC COILS IDENTIFICATION CODE

**C 25.4 - K1 / 11**

#### Supply voltage

- A24** = 24 V - 50 Hz
- A48** = 48 V - 50 Hz
- A110** = 110 V - 50 Hz
- 120 V - 60 Hz
- A230** = 230 V - 50 Hz
- 240 V - 60 Hz
- F110** = 110 V - 60 Hz
- F220** = 220 V - 60 Hz

Series no.:  
(the overall and mounting dimensions remain unchanged from 10 to 19)

plug for connector type  
DIN 43650 (**standard**)

### SEALS KIT

The codes here below include O-Rings ref. 2, 4, 6 and 7.

- Cod. 1984420** NBR seals
- Cod. 1984421** FPM (viton) seals

1	Coil locking ring cod. 0119402
2	OR type 4100 (24.99x3.53)- 90 Shore
3	Coil (see identification code)
4	OR type 2112 (2.9x1.78) - 90 Shore
5	Solenoid tubes: TA25.4-M27/11N (NBR seals) TA25.4-M27/11V (FPM seals) <b>NOTE:</b> the tube is supplied with OR n° 6.
6	OR type 3-912 (23.47x2.95) - 70 Shore
7	N. 5 OR type 2050 (12.42x1.78) - 90 Shore

## 15 - FASTENING BOLTS

4 bolts M6x40 (class 12.9 recommended)  
Tightening torque 8 Nm

## 16 - SUBPLATES (See catalogue 51 000)

Type PMD4-AI4G with rear ports 1/2" BSP

Type PMD4-AL4G with side ports 1/2" BSP



**DIPLOMATIC OLEODINAMICA SpA**  
20025 LEGNANO (MI) - P.le Bozzi, 1 / Via Edison  
Tel. 0331/472111 - Fax 0331/548328