



**DIPLOMATIC
HYDRAULICS**

21 300/107 ED



RQ*-P

PRESSURE RELIEF VALVES

SERIES 41

SUBPLATE MOUNTING

RQ3-P ISO 6264-06 (CETOP R06)

RQ5-P ISO 6264-08 (CETOP R08)

RQ7-P ISO 6264-10 (CETOP R10)

HYDRAULIC SYMBOL

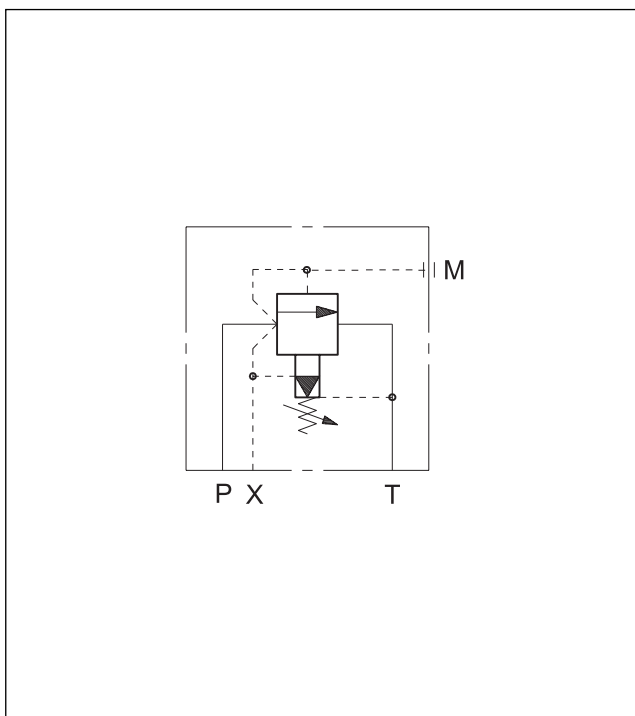

OPERATING PRINCIPLE

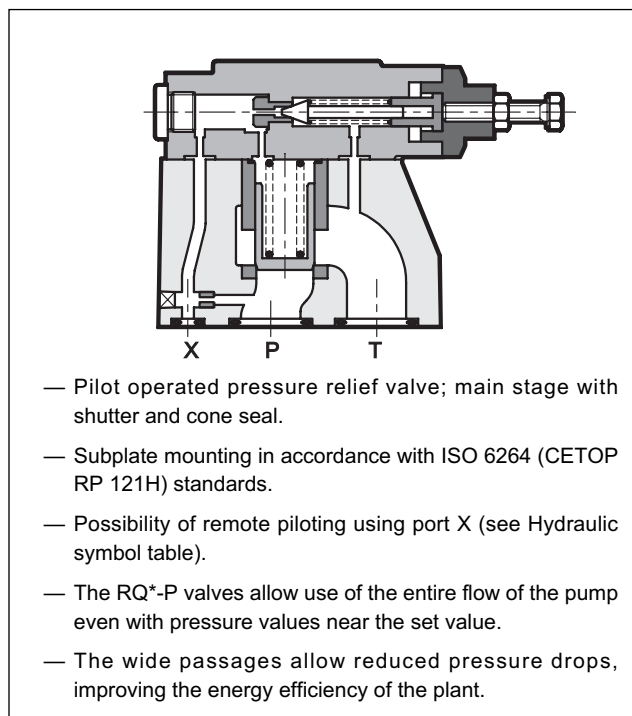

PERFORMANCES (measured with mineral oil of viscosity 36 cSt at 50°C)

		RQ3-P	RQ5-P	RQ7-P
Maximum operating pressure	bar	350		
Maximum flow rate	l/min	200	400	500
Ambient temperature range	°C	-20 / +50		
Fluid temperature range	°C	-20 / +80		
Fluid viscosity range	cSt	10 + 400		
Fluid contamination degree	According to ISO 4406:1999 class 20/18/15			
Recommended viscosity	cSt	25		
Mass	kg	3,5	4,3	6,5



1 - IDENTIFICATION CODE

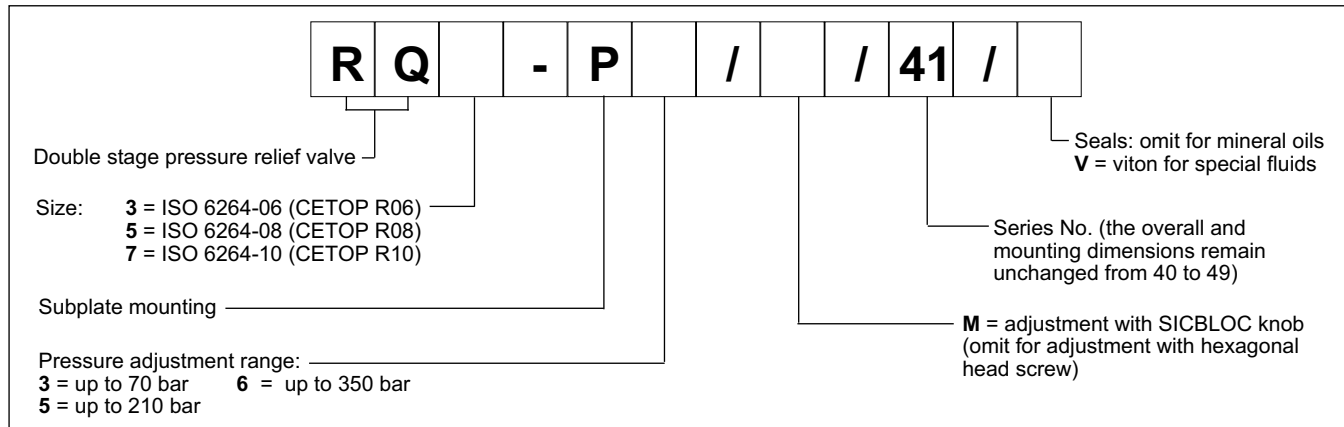

2 - CHARACTERISTIC CURVES (values obtained with viscosity of 36 cSt at 50°C)

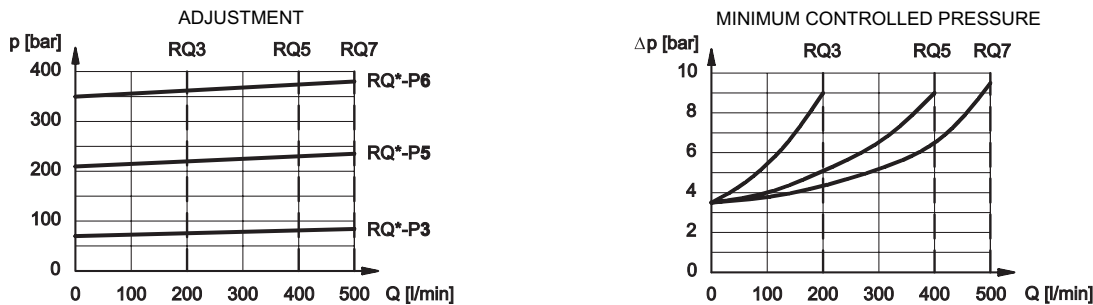

3 - HYDRAULIC FLUIDS

Use mineral oil-based hydraulic fluids HL or HM type, according to ISO 6743-4. For these fluids, use NBR seals. For fluids HFDR type (phosphate esters) use FPM seals (code V). For the use of other kinds of fluid such as HFA, HFB, HFC, please consult our technical department. Using fluids at temperatures higher than 80 °C causes a faster degradation of the fluid and of the seals characteristics. The fluid must be preserved in its physical and chemical characteristics.

4 - RQ3-P OVERALL AND MOUNTING DIMENSIONS

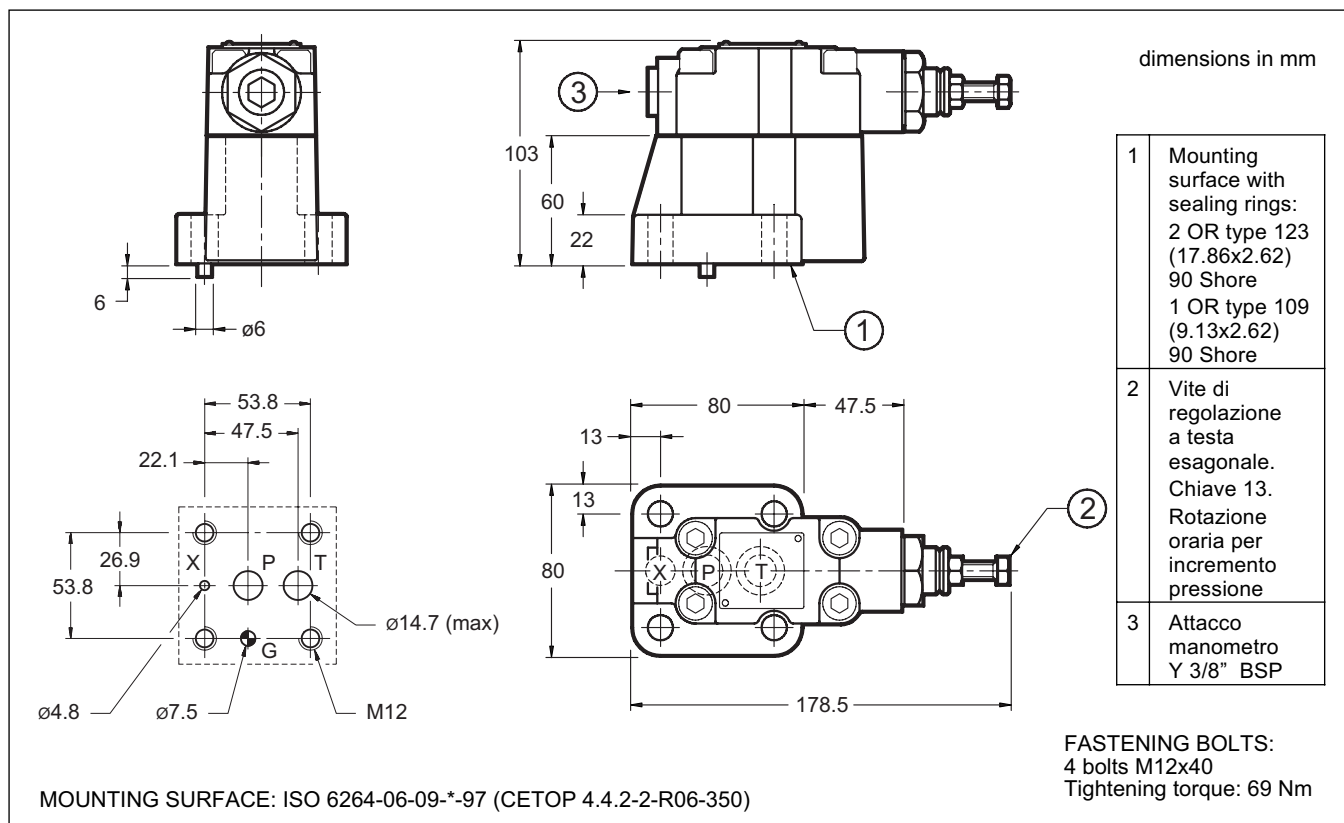



RQ*-P

SERIES 41

5 - RQ5-P OVERALL AND MOUNTING DIMENSIONS

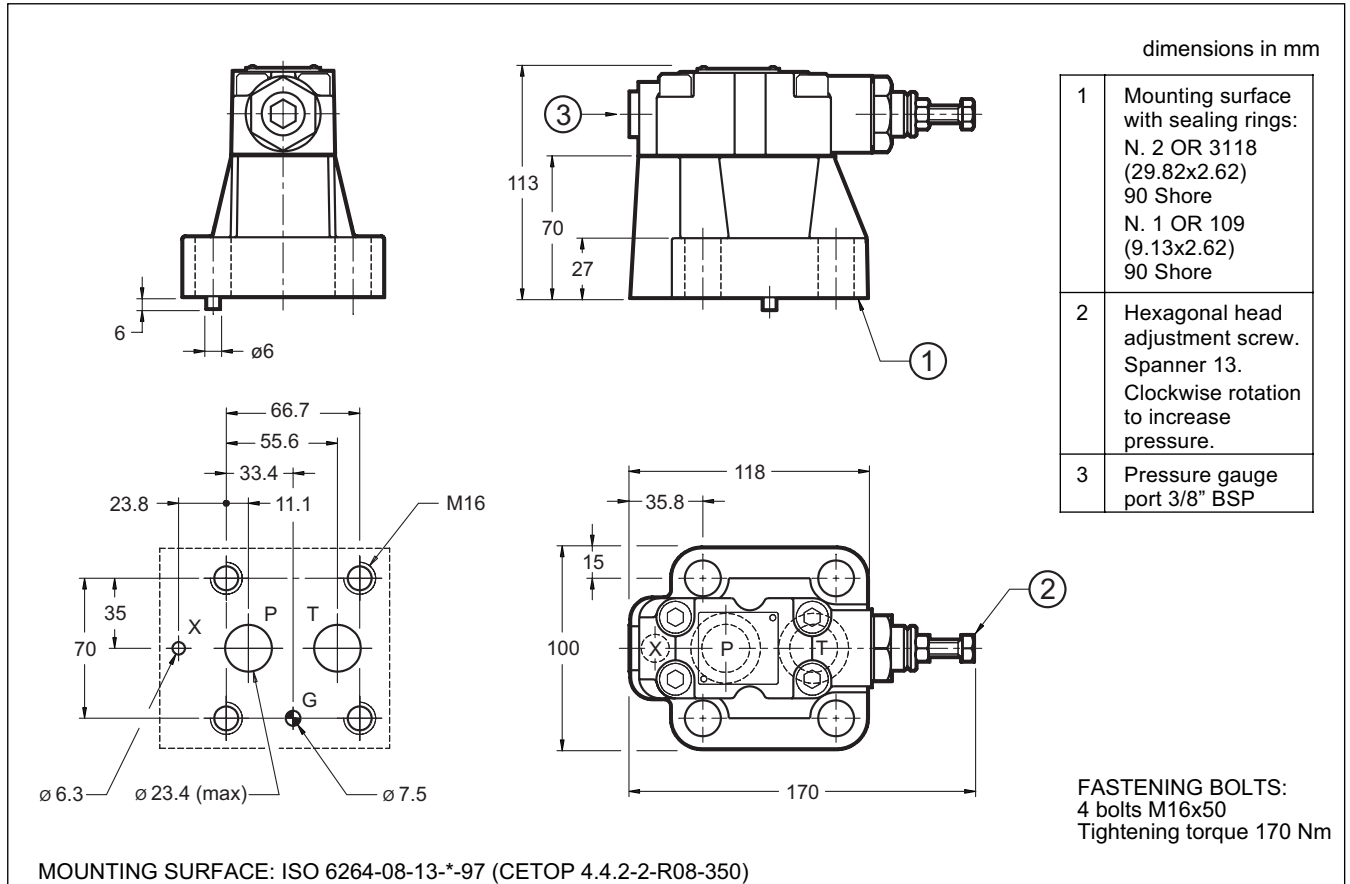

6 - RQ7-P OVERALL AND MOUNTING DIMENSIONS

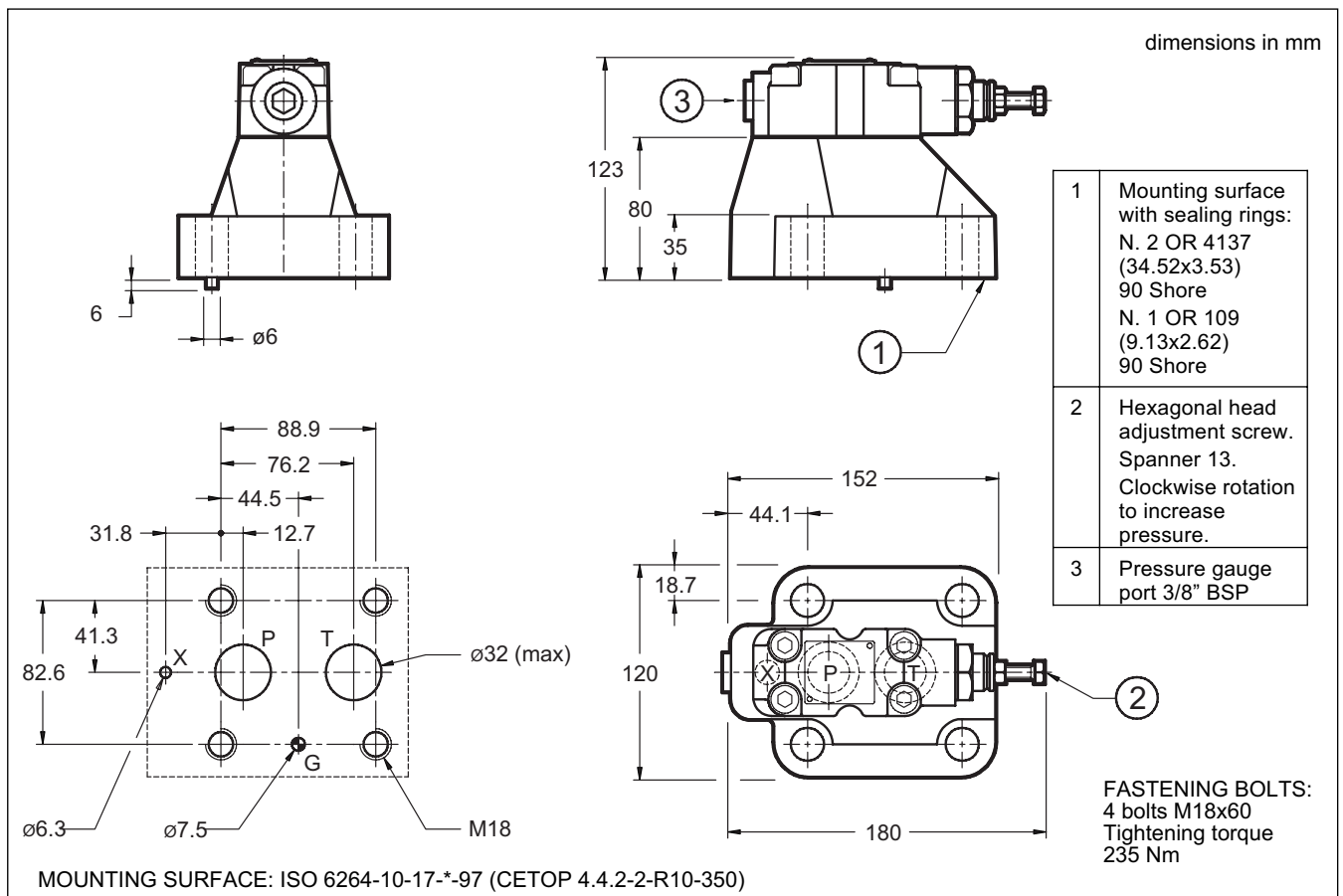



7 - ADJUSTMENT KNOB

The RQ valves can be equipped with a SICBLOC adjustment knob.
To operate it, push and rotate at the same time.
To request this option, add: /M (see paragraph1).

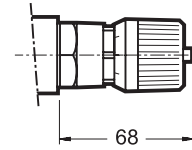

8 - SUBPLATES (see catalogue 51 000)

	RQ3-P	RQ5-P	RQ7-P
Type	PMRQ3-AI4G with rear ports	PMRQ5-AI5G with rear ports	PMRQ7-AI7G with rear ports
Port dimension PT	1/2" BSP	3/4" BSP	1" 1/4 BSP
Port dimension X	1/4" BSP	1/4" BSP	1/4" BSP